



## Modular multi-function meter

### ➤ Function

The **DIRIS A10** is a multi-function meter for measuring electrical values in low voltage networks in modular format. It allows all electrical parameters to be displayed and the measurement, energy metering and communication functions to be used.

In addition, the DIRIS A10 has a function for correcting errors in CT connections. It also allow variations in temperature to be detected thanks to its internal temperature measurement function.

### ➤ Conformity to standards

- IEC 62053-22 class 0,5 S
- IEC 62053-23 class 2
- IEC 61557-12

### ➤ Applications

#### Multi measurement

- Current
  - instantaneous: I1, I2, I3, In
  - mean maximum: I1, I2, I3, In
- Voltages & frequency
  - instantaneous: U1, U2, U3, U12, U23, U31, F
- Power
  - instantaneous: 3P, ΣP, 3Q, ΣQ, 3S, ΣS
  - mean maximum: ΣP, ΣQ, ΣS
- Power factor
  - instantaneous: 3PF, ΣPF

#### Metering

- Active energy: + kWh
- Reactive energy: + kvarh
- Hours: ☉

#### Harmonic analysis (level 51)

- Total harmonic distortion
  - Currents: thd I1, thd I2, thd I3
  - Phase-to-neutral voltage: thd U1, thd U2, thd U3
  - Phase to phase voltage: thd U12, thd U23, thd U31

#### Dual tariff function

Selection of one out of 2 billing tariffs

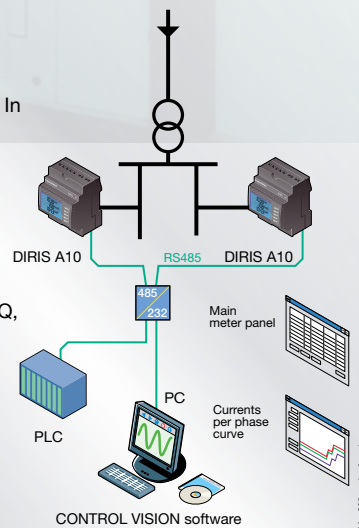

#### Events

Alarms on all electrical values

#### Communications<sup>(1)</sup>

RS485 (JBUS/MODBUS) digital

#### Output

- Control of apparatus
- Alarm report
- Pulse report

(1) Available as an option  
(see the following pages).

## Front panel



1. Backlit LCD screen.
2. Direct access key for currents (instantaneous and max. values), current THD and set up wiring correction.
3. Direct access key for voltages, frequency and voltage THD.
4. Direct access key for active, reactive and apparent power (instantaneous and max. values) and power factor.
5. Direct access key for energies and hour meter.
6. Pushbutton for currents, temperatures and CT setup wiring correction.
7. Flashing led consumption.

## Case

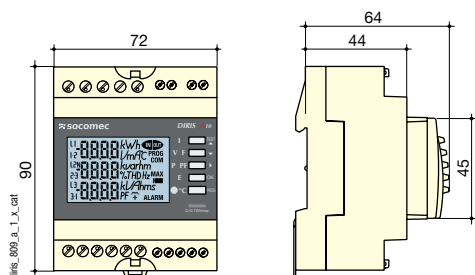

Type	Modular
Number of optional modules	4
Dimensions W x H x D	72 x 90 x 64 mm
Case protection index	30
Front protection rating	52
Display type	LCD
Weight	205 g (48250210) - 215 g (48250211)
Voltage and other connection section	4 mm <sup>2</sup>
Other connection section	2.5 mm <sup>2</sup>

## Electrical Characteristics

### Current measurement on insulated inputs (TRMS)

CT primary	9 999 A
CT secondary	5 A
Measurement range	0 ... 11 kA
Input consumption	0,6 VA
Measurement updating period	1 s
Accuracy	0.2 %
Sustained overload	6 A
Intermittent overload	10 I <sub>n</sub> for 1 s

### Voltage measurements (TRMS)

Direct measurement between phases	50 ... 500 VAC
Direct measurement between phase and neutral	28 ... 289 VAC
Input consumption	≤ 0,1 VA
Measurement updating period	1 s
Accuracy	0.2 %
Sustained overload	800 VAC

### Power measurement

Measurement updating period	1 s
Accuracy	0.5 %

### Power factor measurement

Measurement updating period	1 s
Accuracy	0.5 %

### Frequency measurement

Measurement range	45 ... 65 Hz
Measurement updating period	1 s
Accuracy	0.1 %

### Energy accuracy

Active (according to IEC 62053-22)	class 0.5 S
Reactive (according to IEC 62053-23)	class 2

### Auxiliary power supply

Alternating voltage	200 ... 277 VAC
AC tolerance	± 15 %
Frequency	50 / 60 Hz
Consumption	< 3 VA

### Outputs (Pulse)

Number	1
Type	100 VDC - 0.5 A - 10 VA
Max. number of operations	≤ 10 <sup>8</sup>

### Communication

Link	RS485
Type	2 ... 3 half duplex wires
Protocol	JBUS/MODBUS® in RTU mode
JBUS/MODBUS® speed	1400 ... 38400 bauds

### Operating conditions

Operating temperature	- 10 ... + 55°C °C
Storage temperature	- 20 ... + 70°C °C
Relative humidity	85 %

## ➔ Connection

### Low voltage balanced network

#### Recommendation:

- For IT earthing systems, it is recommended that the CT secondaries are not connected to the earth.
- While disconnecting the DIRIS, the secondaries of each current transformer must be short-circuited. This operation can be carried out automatically from a product in the SOCOMEC catalogue, PTI: Please consult us.
- It is recommended that the earthing point for the DIRIS A10 and the current transformer secondaries must not be earthed at the same time.

#### 3/4 wires with 1 CT

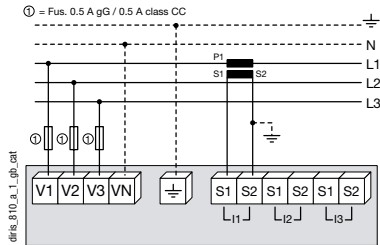

#### Single phase

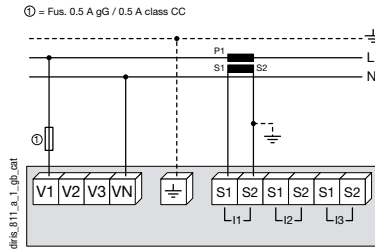

#### Two phase

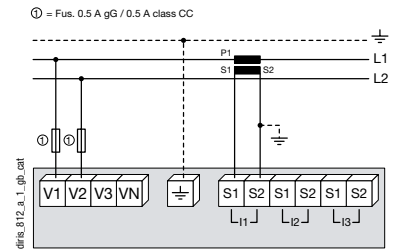

### Connection - Low voltage unbalanced network

#### 3/4 wires with 3 CTs

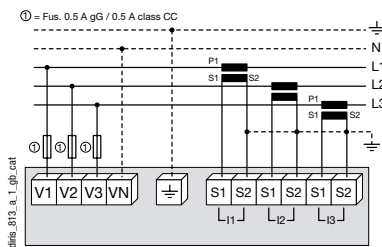

#### 3 wires with 2 CTs

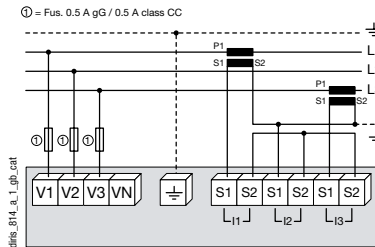

Use of 2 CTs reduces by 0.5 % the accuracy of the phase, whose current is worked out by vector calculation.

#### 3 wires with 2 CTs

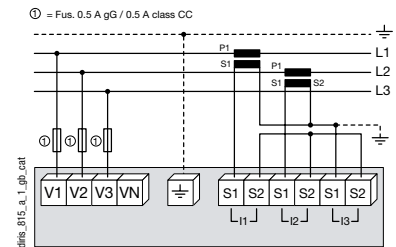

Use of 2 CTs reduces by 0.5 % the accuracy of the phase, whose current is worked out by vector calculation.

### Other information

#### Communication via RS485 link

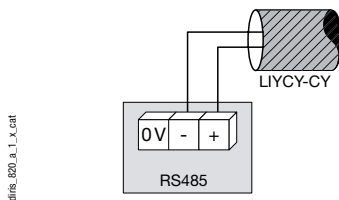

#### AC & DC auxiliary power supply

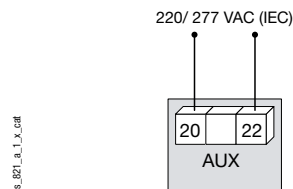

It is recommended that the auxiliary power supply must be protected by the use of 500 mA gG fuses.

➤ **Terminals**

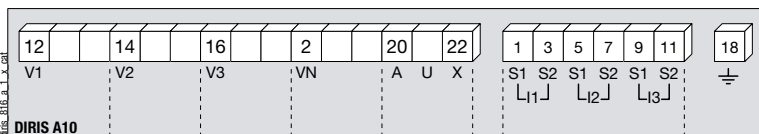

**DIRIS A10**  
S1 - S2: current inputs.

AUX: auxiliary power supply  $U_a$   
V1, V2, V3 & VN: voltage inputs.

Communication module

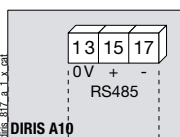

**DIRIS A10**  
RS485 link.

Output or alarm module

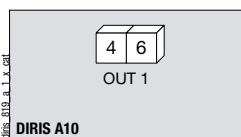

**DIRIS A10**  
4 - 6: output n°1.

Input module

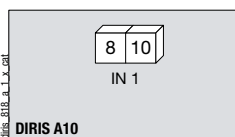

**DIRIS A10**  
8 - 10: input no. 1.

➤ **References**



<b>Switches</b>		<b>DIRIS A10</b>
<b>Description</b>		<b>Reference</b>
DIRIS A10 (grey colour available on request)		4825 0010
DIRIS A10 with JBUS/MODBUS communication via RS485 (grey colour available on request)		4825 0011
<b>Description of accessories</b>		<b>Pack qty</b>
Fuse combination switches for the protection of voltage inputs (type RM) 3 poles	4	5601 0018
Fuse combination switches for the protection of the auxiliary supply (type RM) 1 pole + neutral	6	5601 0017
Fuses type gG 10x38 0.5 A	10	6012 0000
Current transformers range		See page XXX