

# Circuitor

Electronic earth leakage protection relay

**RGU-10, RGU-10C**

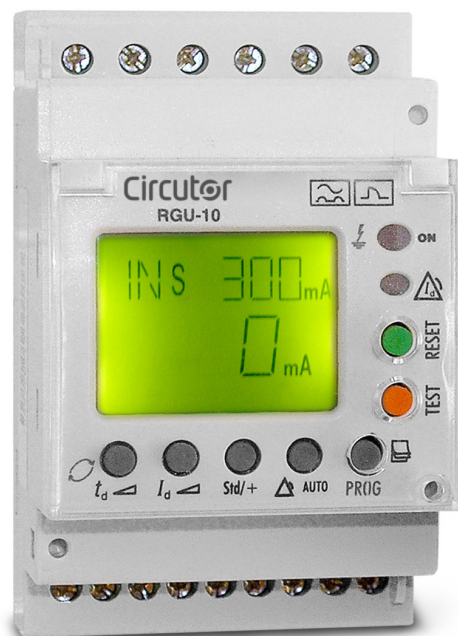

## INSTRUCTION MANUAL

(M98203201-03-21A)







## SAFETY PRECAUTIONS

Follow the warnings described in this manual with the symbols shown below.

	<p><b>DANGER</b> Warns of a risk, which could result in personal injury or material damage.</p>
---	---

	<p><b>ATTENTION</b> Indicates that special attention should be paid to a specific point.</p>
---	--

If you must handle the unit for its installation, start-up or maintenance, the following should be taken into consideration:

	<p>Incorrect handling or installation of the unit may result in injury to personnel as well as damage to the unit. In particular, handling with voltages applied may result in electric shock, which may cause death or serious injury to personnel. Defective installation or maintenance may also lead to the risk of fire.</p> <p>Read the manual carefully prior to connecting the unit. Follow all installation and maintenance instructions throughout the unit's working life. Pay special attention to the installation standards of the National Electrical Code.</p>
---	--

	<p><b>Refer to the instruction manual before using the unit</b></p> <p>In this manual, if the instructions marked with this symbol are not respected or carried out correctly, it can result in injury or damage to the unit and /or installations.</p>
---	---

CIRCUTOR, SA reserves the right to modify features or the product manual without prior notification.

## DISCLAIMER

CIRCUTOR, SA reserves the right to make modifications to the device or the unit specifications set out in this instruction manual without prior notice.

CIRCUTOR, SA on its web site, supplies its customers with the latest versions of the device specifications and the most updated manuals.

[www.circutor.com](http://www.circutor.com)



	<p><b>CIRCUTOR</b>, recommends using the original cables and accessories that are supplied with the device.</p>
---	---

## CONTENTS

SAFETY PRECAUTIONS .....	3
DISCLAIMER .....	3
CONTENTS.....	4
REVISION LOG .....	5
SYMBOLS.....	5
1.- VERIFICATIONS UPON RECEPTION .....	6
2.- DESCRIPTION OF THE PRODUCT.....	6
3.- INSTALLING THE DEVICE.....	8
3.1.- PRELIMINARY RECOMMENDATIONS .....	8
3.2.- INSTALLATION .....	9
3.2.1.- INSTALLATION OF DEVICE IN PANEL .....	9
3.3.- TERMINALS OF THE DEVICE.....	10
3.4.- CONNECTION DIAGRAMS.....	11
3.4.1.- CONNECTION WITH CURRENT EMISSION COIL .....	11
3.4.2.- CONNECTION WITH UNDERVOLTAGE COIL.....	16
3.4.3.- CONNECTING THE DEVICE IN POSITIVE SAFETY .....	19
4.- OPERATION.....	21
4.1.- GENERAL DESCRIPTION.....	21
4.2.- DESCRIPTION OF THE DEVICE .....	22
4.3.- LEDs INDICATORS.....	22
4.4.- KEYBOARD FUNCTIONS.....	23
4.5.- DISPLAY.....	24
4.6.- OPERATION.....	25
4.7.- TROUBLESHOOTING OR REASONS FOR TRIPPING .....	26
4.7.1.- POOR TOROID CONNECTION ALARM.....	26
4.7.2.- PRE-ALARM TRIP.....	26
4.7.3.- FAULT TRIP .....	27
4.7.4.- REMOTE TRIP .....	27
5.- CONFIGURATION .....	28
5.1.- DIRECT SETTING .....	28
5.1.1.- SETTING THE SENSITIVITY TRIP .....	28
5.1.2.- DELAY SETTING AND MAIN RELAY CURVE.....	28
5.1.3.- POSITIVE SECURITY SETTING OF THE MAIN RELAY.....	29
5.1.4.- SETTING THE PRE-ALARM RELAY .....	29
5.2.- SETTING BY SETUP .....	31
5.3.- CONFIGURATION THE MEASUREMENT SETUP.....	32
5.3.1.- OPERATING FREQUENCY .....	32
5.3.2.- SCALE LIMIT .....	33
5.4.- CONFIGURATION THE COMMUNICATION SETUP .....	33
5.4.1.- PERIPHERAL NUMBER.....	34
5.4.2.- BAUD RATE .....	34
5.4.3.- PARITY .....	35
6.- RS-485 COMMUNICATIONS .....	36
6.1.- CONNECTIONS .....	36
6.2.- MODBUS PROTOCOL.....	37
6.2.1. READ EXAMPLE: Function 0x04.....	37
6.2.2. WRITE EXAMPLE: Function 0x10.....	38
6.3.- MODBUS COMMANDS.....	38
7.- TECHNICAL FEATURES .....	40
8.- TECHNICAL SERVICE .....	42
9.- WARRANTY.....	42
10.- CE CERTIFICATE.....	43







## REVISION LOG

Table 1: Revision log.

Date	Revision	Description
05/18	M98203201-03-18A	New Version
03/19	M98203201-03-19A	Change in the following sections: 4.5. - 4.7.1.
04/21	M98203201-03-21A	Change in the following sections: 3.4.1.1. - 3.4.2.1.

## SYMBOLS

Table 2: Symbols.

Symbol	Description
	In compliance with the relevant European directive.
	In compliance with the CMiM directive.
	In compliance with the UKCA (UK Conformity Assessed) directive.
	The device complies with the 2012/19/EC European directive. Do not dispose of the device in a household waste container at the end of its useful life. Observe the local electronic device recycling regulations.
	Direct current.
	Alternating current.

**Note:** The images of the devices are for illustrative purposes only and might differ from the original device.

## 1.- VERIFICATIONS UPON RECEPTION

The following must be checked upon reception of the device:

- a) The device has been supplied according to the specifications in your order.
- b) The device has not been damaged during transport.
- c) Perform an external visual inspection of the device before connecting it.
- d) Check that it has been supplied with the following:

- An installation guide.



Immediately contact the carrier and/or **CIRCUITOR's** after-sales service if you detect any problem in the device upon reception.

## 2.- DESCRIPTION OF THE PRODUCT

The **RGU-10** earth leakage relay is type A programmable electronic earth leakage protection device with two independent relays: the main output for checking the cut off device and performing the protection function and the pre-alarm relay for installation prevention and maintenance.



Allows the setting and adjustment of all parameters required for complete protection and maintenance checking in the installation. A series of parameters may be set directly from the keyboard (buttons) and by setting menus on the device itself.

Before starting the earth leakage device carefully read sections: power supply, connection diagram and setting.

The **RGU-10** measures, calculates and displays the earth leakage current in three-phase, balanced or unbalanced industrial systems.

Measurements are in true effective value, via one earth leakage current input, from the **WGC** family external measuring toroid.

Under normal operating conditions the main values determining earth leakage protection in an installation are shown on the display. These include sensitivity, delay and instant current leakage. Bearing in mind the high degree of protection required by installations, the device has a display and

LED indicators for the different events which usually occur.

Data displayed or pre-alarm indication, trips, leakage readings, etc. assist in providing sufficient information for proper maintenance.

Under normal operating conditions the backlit display is green. However, after any event causing a main relay to trip, the backlight is red, indicating the reason.

The version for RS-485 communications (**RGU-10C**) and appropriate software allows setting, data and information to be centralised for the proper monitoring and checking of the maintenance of electricity lines.

The measurement of earth leakage current from which **the RGU-10/RGU-10C** operates by indicating the instant leakage current, pre-alarm or trip is determined by the WGC series earth leakage transformers. The inner diameter of the transformer is defined by the installation's wiring dimensions.

There are 2 models of the device:

- ✓ **RGU-10**, without communications.
- ✓ **RGU-10C**, with communications RS-485.

Main features:

- Measuring in true effective value (TRMS)
- Type A differential (IEC 61008.1)
- Insulation against transients (IEC 61008.1)
- High frequency filtering (IEC 61008.1)
- Trip setting between 80 and 100%  $I_{\Delta n}$
- Inverse curve (IEC 61008.1)
- Associated standard : IEC 61008.1, IEC755
- 3 modules. DIN rail. In a panel using front accessory
- Displaying instant leakage values.
- Backlit LCD display.
- **RGU-10C Model** : Built-in RS485 communications (Modbus RTU®).

### 3.- INSTALLING THE DEVICE

#### 3.1.- PRELIMINARY RECOMMENDATIONS



The operators using and handling the device must follow the safety measures established in the country where the device will be used to guarantee its safe operation, using personal protective equipment if needed.

The **RGU-10** device must be installed by authorised and qualified staff.

Disconnect the device from the mains and disconnect the measuring devices before handling, changing the connections of or replacing the device. Handling the device while it is connected is hazardous to people nearby.

The cables must be in perfect working order to prevent accidents or injuries to people and/or damage to the facilities/installations.

Limit the operation of the device to measuring the specified current or voltage values.

The manufacturer of the device shall not be held responsible for any damage resulting from the user or installation company failing to observe the warnings and/or recommendations indicated in this manual nor for any damage resulting from the use of non-original products or accessories or those from other brands.

Do not use the device to take measurements if you detect an anomaly or malfunction.

Check the environment in which the device is installed before taking a measurement. Do not use the device to take measurements in dangerous, explosive, wet or damp environments.



Disconnect the device from the mains and from the power supply (both the device and its measuring system) before performing any maintenance work, repairs or handling any of the connections of the device.  
Contact the after-sales service if you detect that the device is not working properly.



## 3.2.- INSTALLATION



While the device is connected, the terminals, opening the cover or removing elements can expose parts that are hazardous to the touch. The device must not be used until the installation process is complete.

The device is installed on a DIN rail or on a panel (drilled panel  $67^{+1} \times 67^{+1}$ mm, according to DIN 43 700 using accessory). All connections must remain inside the electrical board.

### 3.2.1.- INSTALLATION OF DEVICE IN PANEL

A 72x72 mm front adapter accessory is used to install the device on a panel. All connections must remain inside the electrical board.

The front adapter accessory has a base, a frame two tabs and three screws, **Figure 1**.



Figure 1:Adapter accessory.

The steps to follow to perform the installation of the adapter accessory are:

- 1.- The base is mounted on top of the device.
- 2.- The device is attached by screwing the holes in the device on the upper right corner and lower left corner on the front of device.
- 3.- The front frame is attached to cover the mounting points.
- 4.- Three green pressure tabs on the side runners of the base are attached.
- 5.- The device is mounted in the hole in the panel with the adapter.
- 6.- The tabs run towards the panel to obtain the mounting pressure.



Figure 2: Installation of adapter accessory

### 3.3.- TERMINALS OF THE DEVICE

Table 3:Terminal description RGU-10.

Terminals of the device	
1: Voltage input ON/OFF external L	9: Toroid current input 1S2
2: Voltage input ON/OFF external N	10: Power supply voltage input A1
4: Output common contact pre-alarm	11: Power supply voltage input A2
5: NC output contact pre-alarm	13: NO output contact trip
6: NO output contact pre-alarm	14: NC output contact trip
8: Toroid current input 1S1	15: Output common contact trip

Note: Terminals 3, 7 and 12 are free.



Figure 3: RGU-10 terminals.



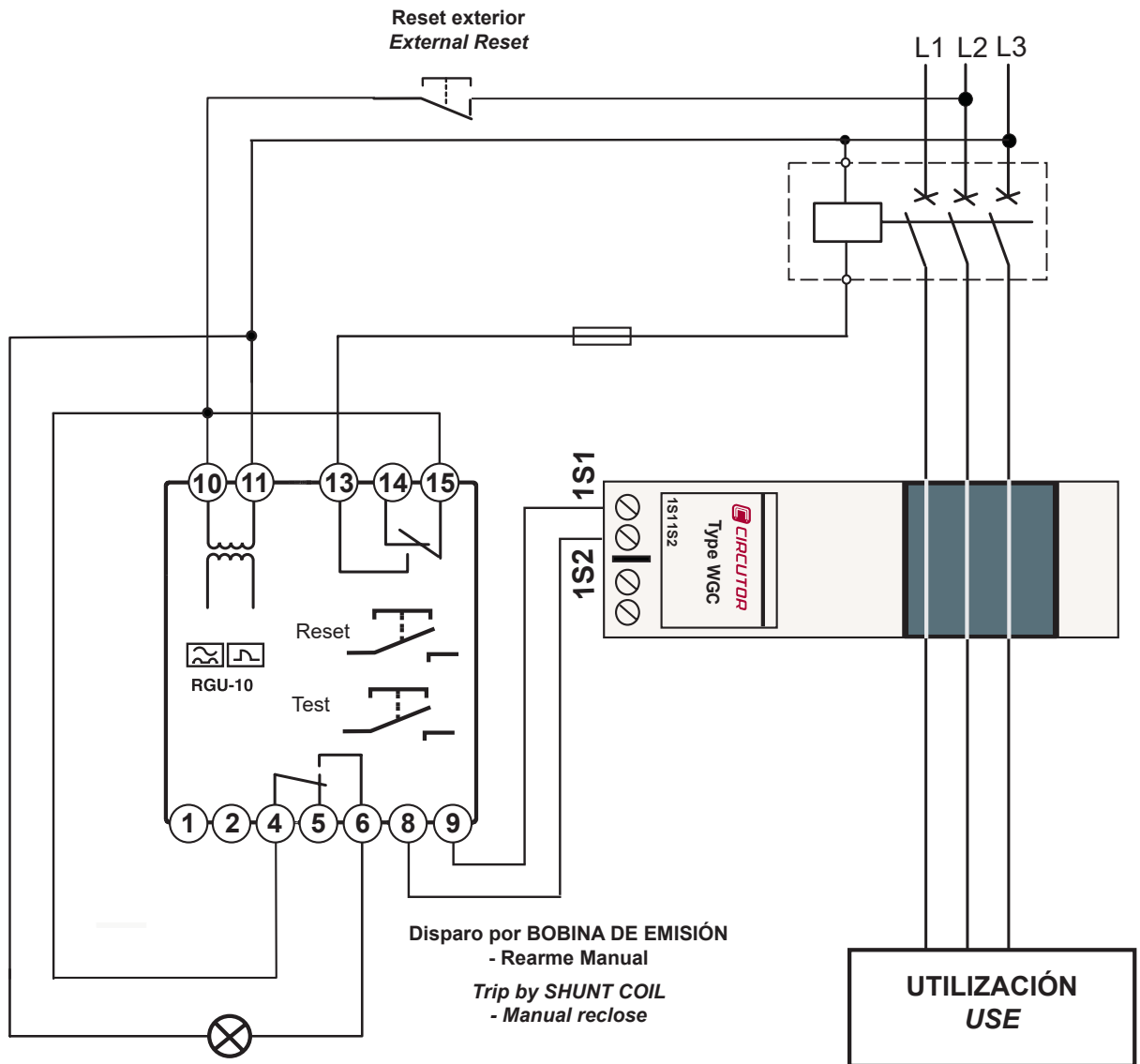

Figure 5: 400 Vac power supply

### 3.4.1.2.- Powering the device after the breaking device

The following has to be taken into consideration in the event of powering device after the breaking device.

- 1.- The breaking device has to be a manually resettable device.
- 2.- After tripping, the device is disconnected losing all information on the reasons for the trip. The system is reset only by resetting the breaking device. It is reconnected by the power supply.

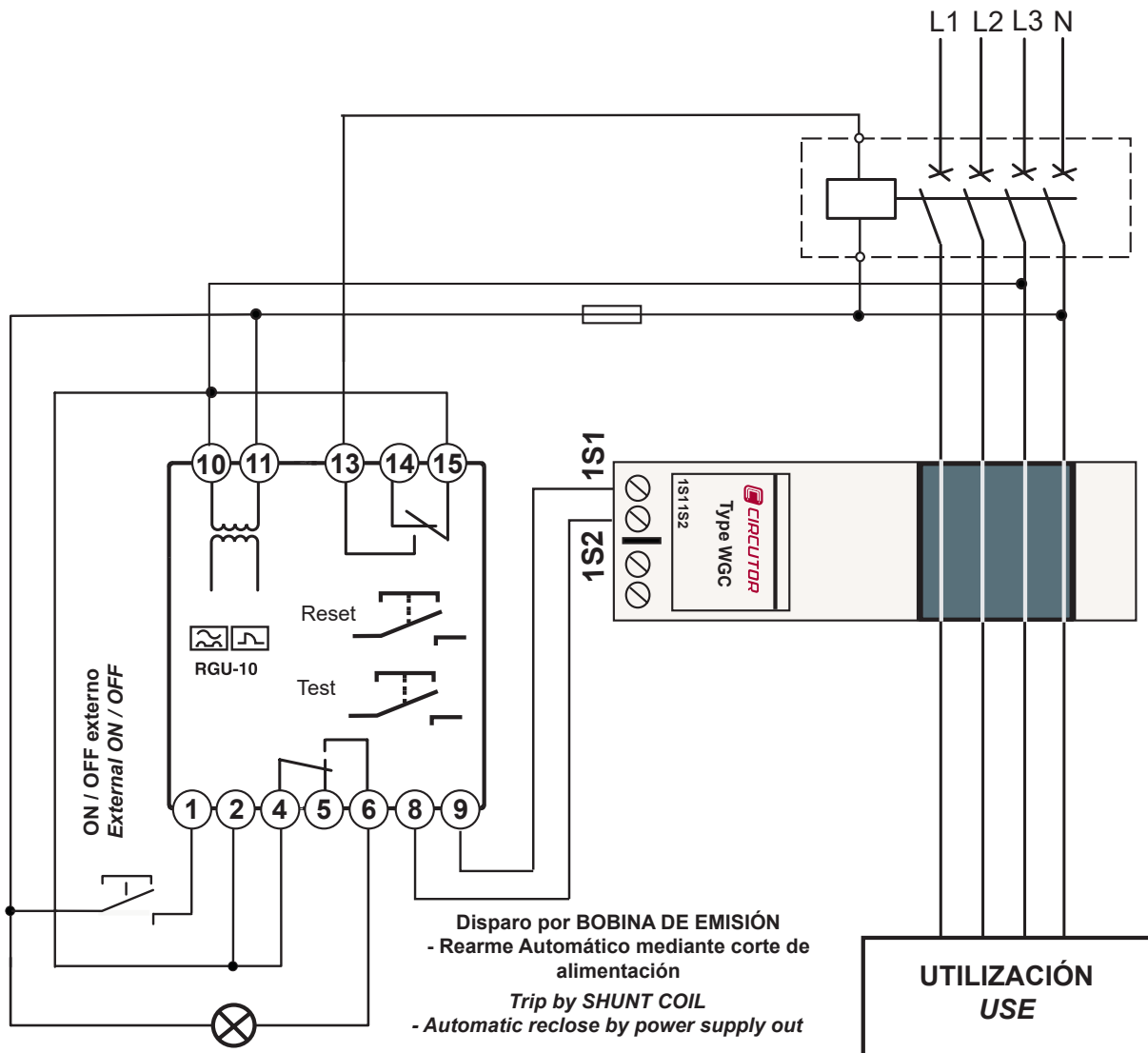

Figure 6: 24 ... 230 Vac power supply

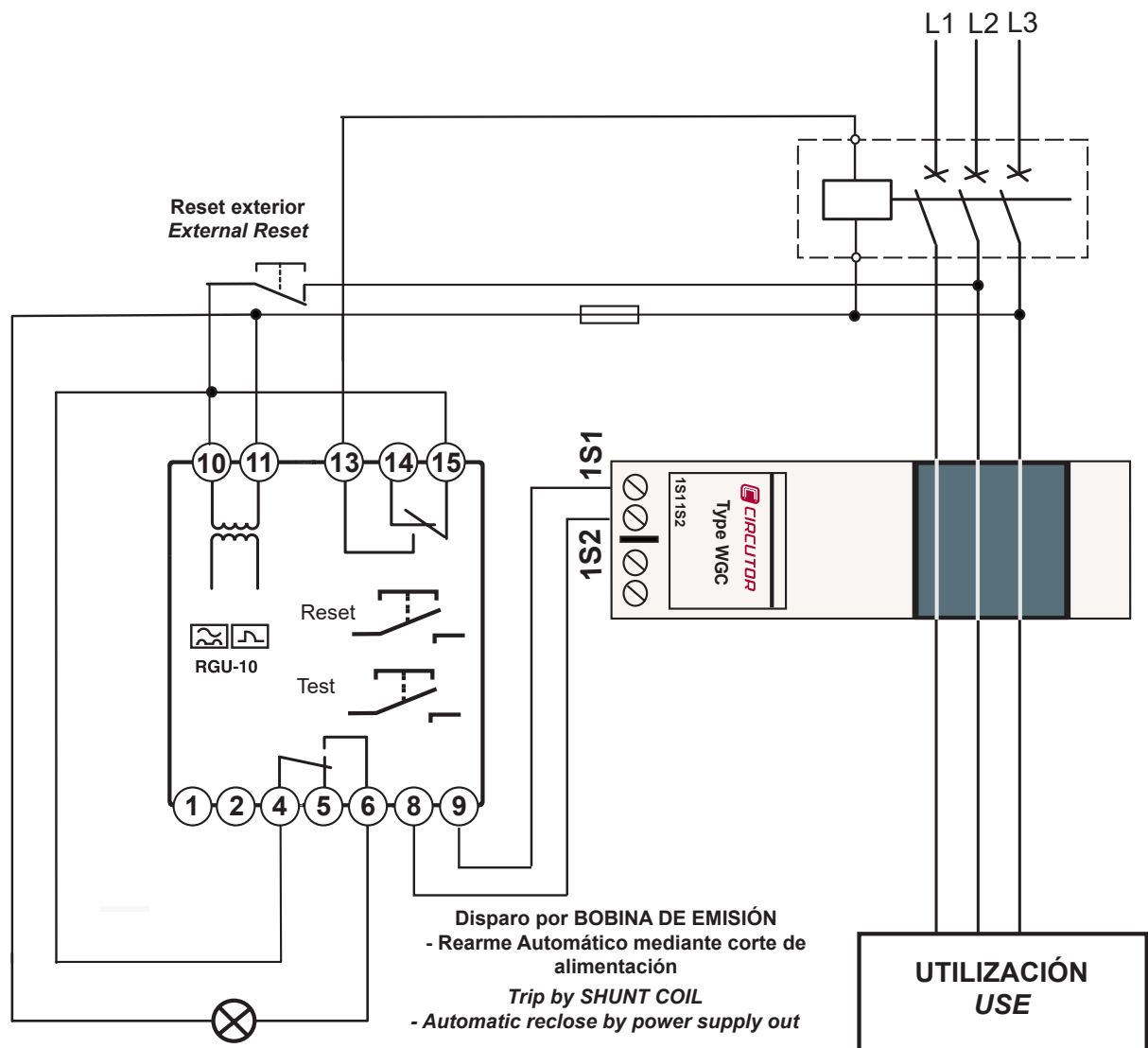

Figure 7: 400 Vac power supply

The device operates to its maximum whenever it is supplied from the installation itself before the breaking device or from an independent auxiliary power supply. However if the power supply from the installation is below the breaking device the system continues to be properly protected even though with limitations in terms of its disconnection performance through lack of power supply.

3.4.1.3.- Power supply of the device independent of the installation

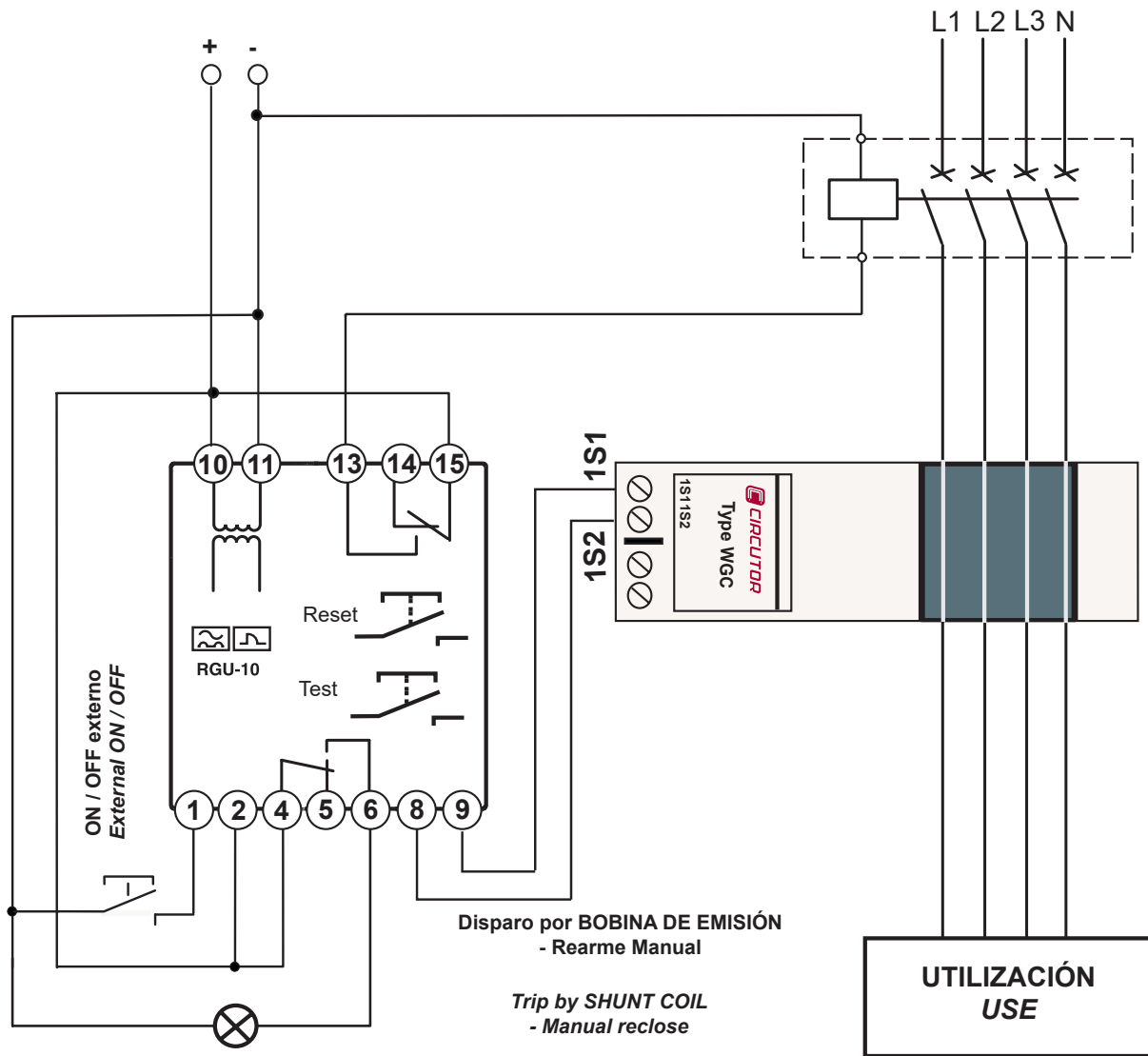

Figure 8: 24 ... 120 Vdc power supply

### 3.4.2.- CONNECTION WITH UNDERVOLTAGE COIL

#### 3.4.2.1.- Powering the device before the breaking device

This breaking device may be an automatic switch or contactor.

Using a **Contactor** the protection is reset by pressing RESET, or by using an **automatic switch**. The breaking device must be rearmed beforehand.

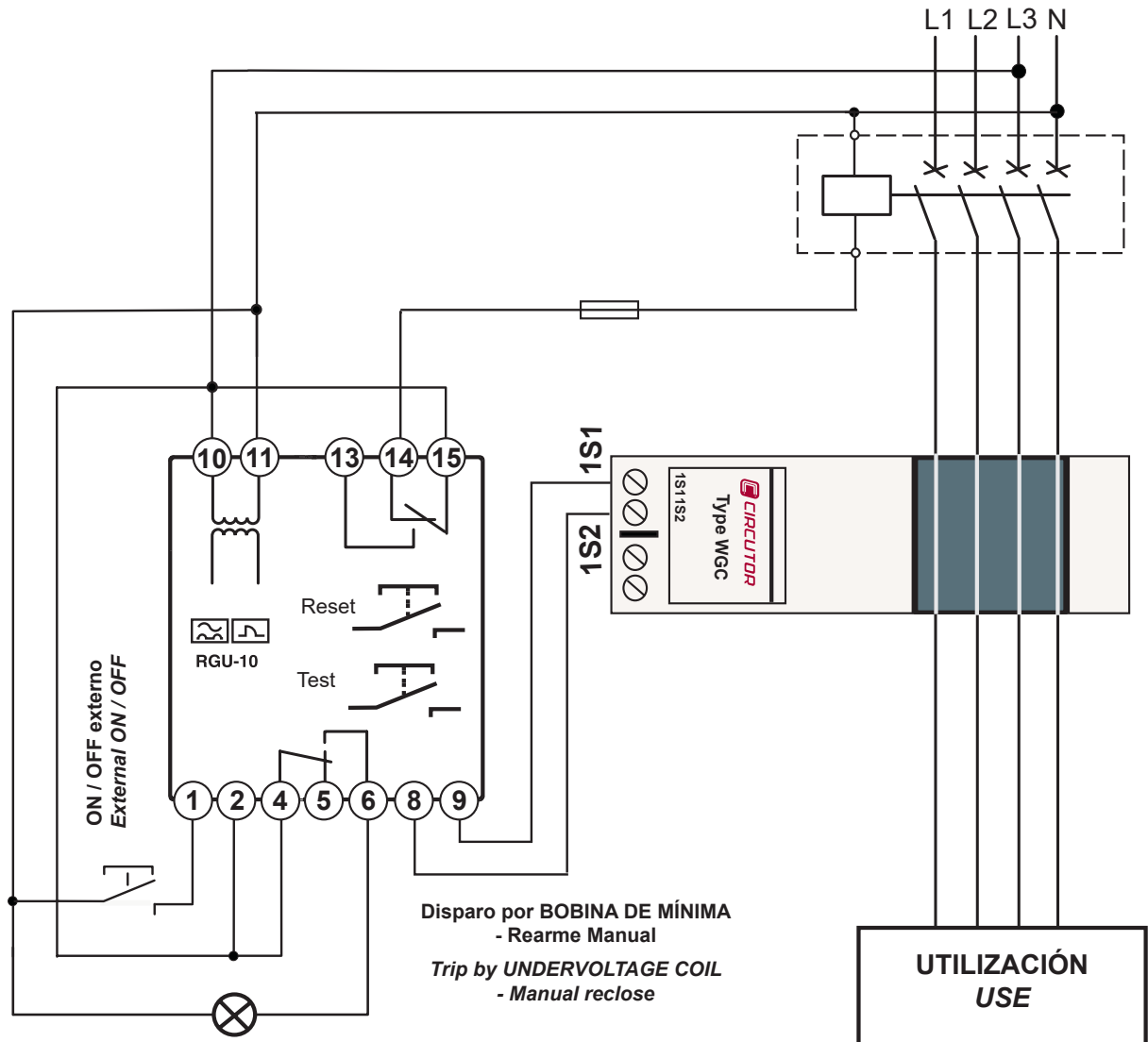

Figure 9: 24 ... 230 Vac power supply



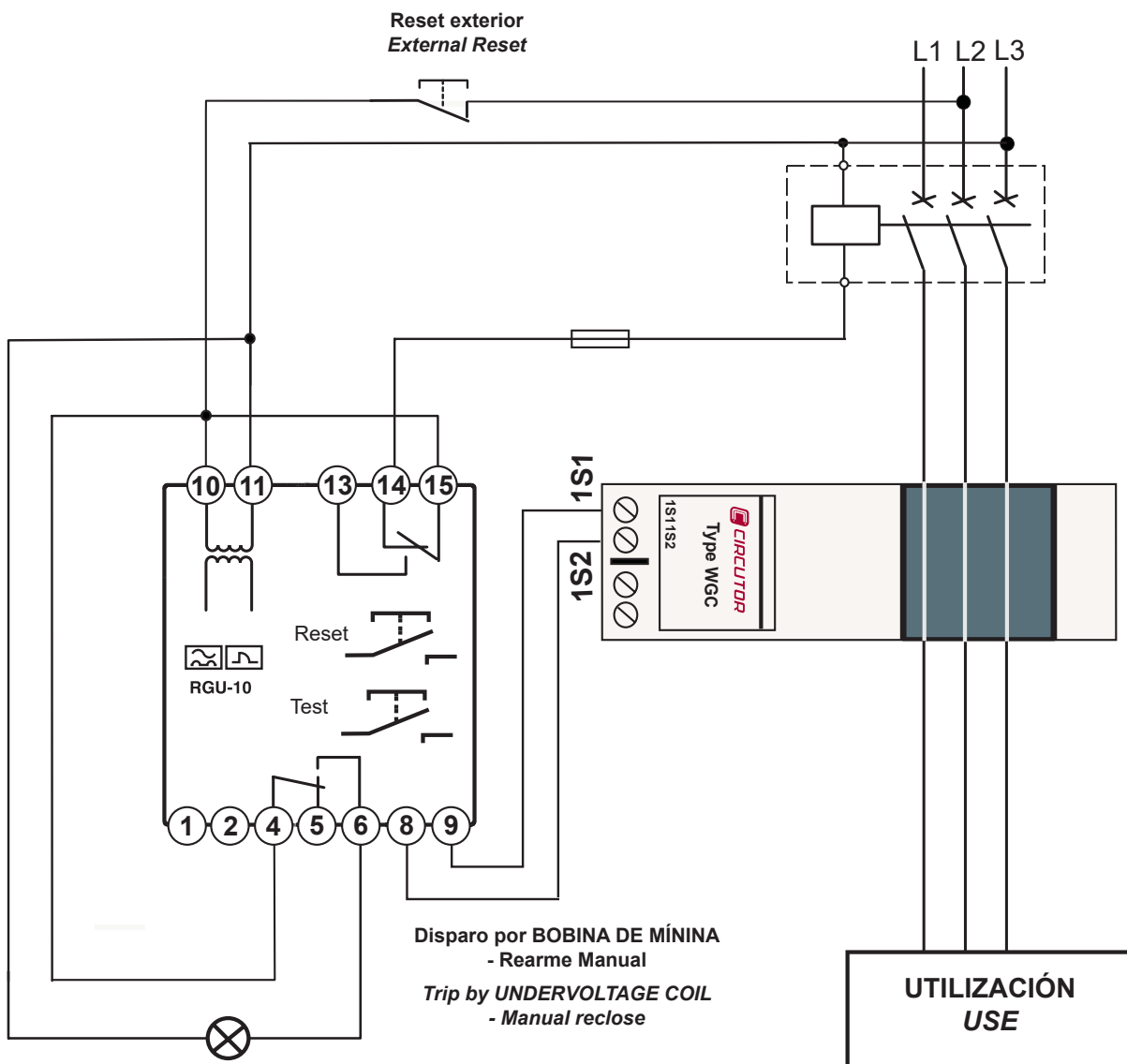

Figure 10: 400 Vac power supply

3.4.2.2.- Power supply of the device independent of the installation

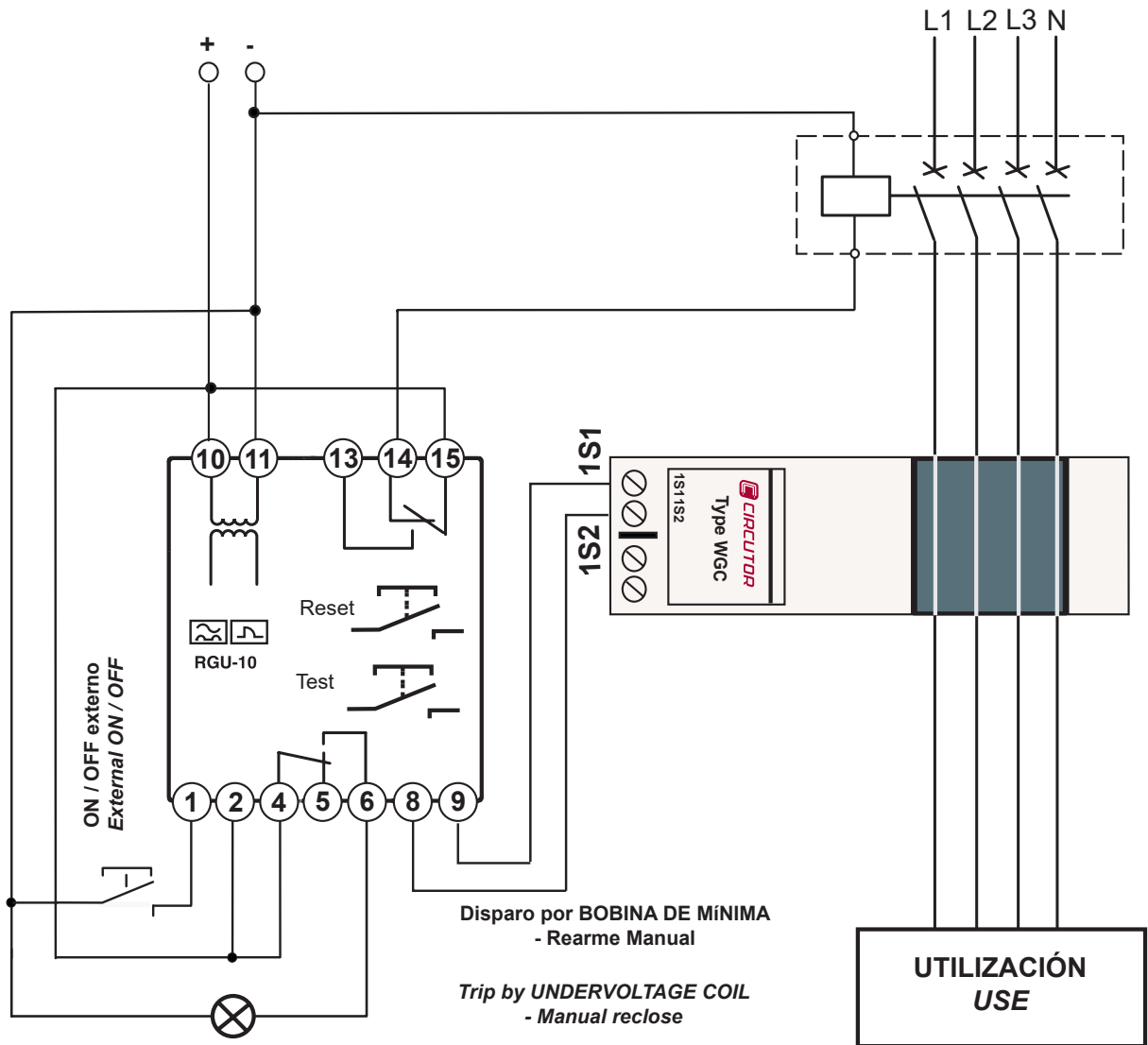

Figure 11: 24 ... 120 Vdc power supply

### 3.4.3.- CONNECTING THE DEVICE IN POSITIVE SAFETY

This installation mode provides the most conservative protection from the point of view of personal and property safety in electrical installations.

With this type of device connection and setting, persons all goods are protected against faults where the earth leakage relay loses its protection capacity. The last order from the relay is to open the installation in the event of this power supply problems to the device itself or through lack of voltage in the installation (neutral or phase fault).

#### 3.4.3.1.- Connection with undervoltage coil

- 1.- The breaking device has the power to trip using the undervoltage coil, either internally (**contactor**) or externally (**automatic switch**).
- 2.- The device is set by programming by pressing **Std/+** key in positive safety mode. The "+" symbol appears on the display.
- 3.- The device's power supply has to be the same as the installation or section it is protecting.

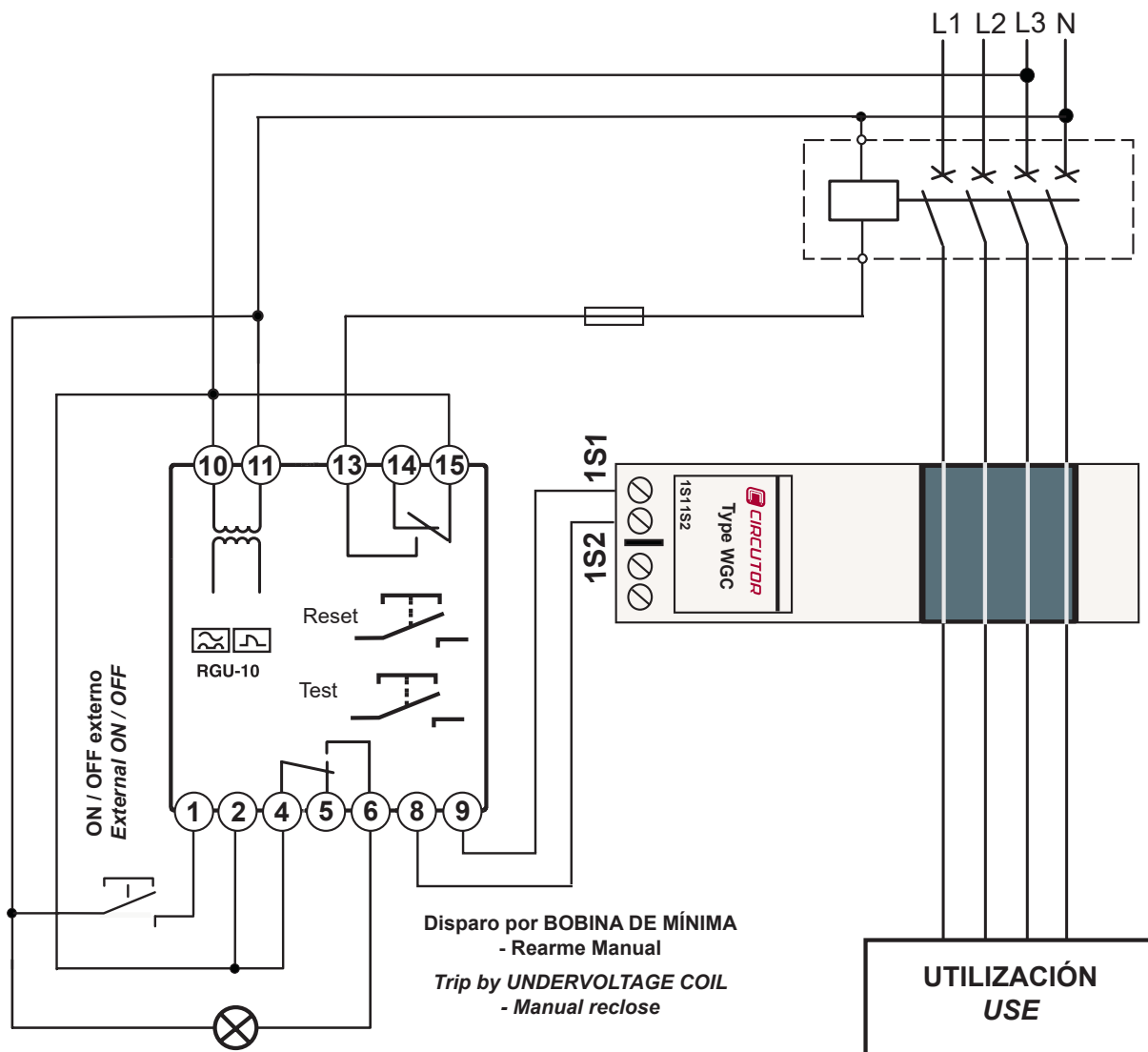
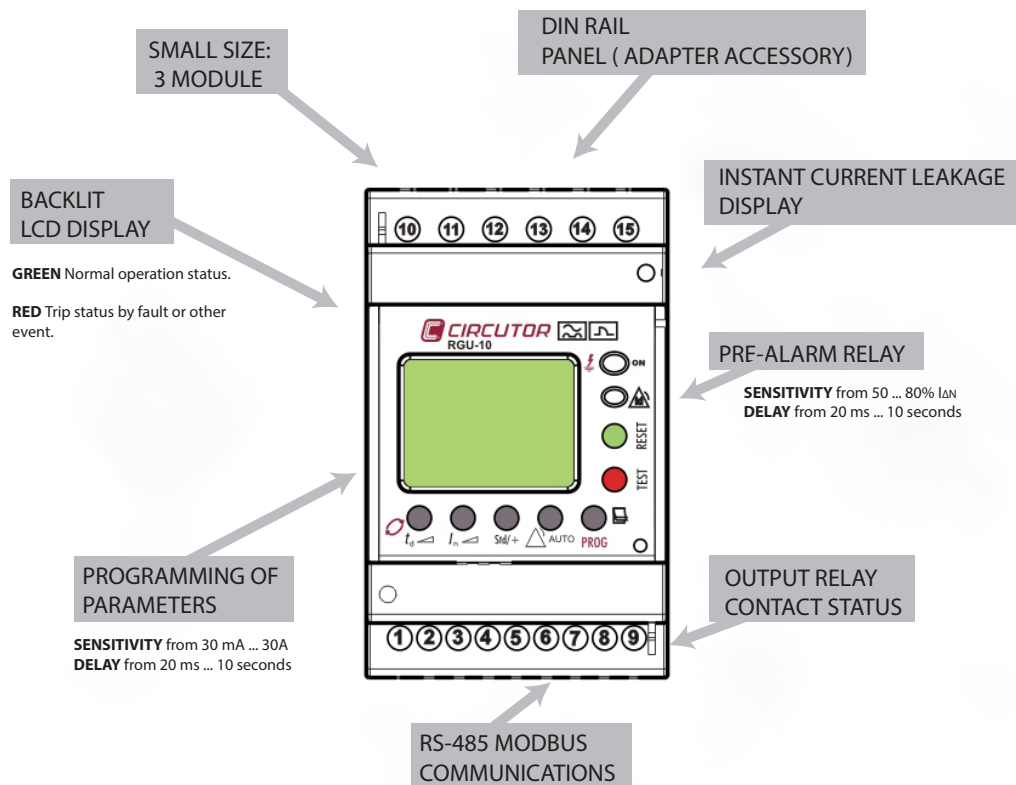

Figure 12: Positive safety, undervoltage coil.



## 4.- OPERATION

### 4.1.- GENERAL DESCRIPTION



### ASSOCIATED BREAKING DEVICE

**CONTACTOR.** Connection by undervoltage coil



**EARTH LEAKAGE DEVICE WITH TRIP COIL**



**TRIP COIL**

- **MINIMUM Voltage**
- **Current EMISSION**

### ASSOCIATED MEASURING DEVICE



**EARTH LEAKAGE TOROIDAL WGC FAMILY**

4.2.- DESCRIPTION OF THE DEVICE

The front of the equipment which is formed by the display, buttons and LEDs, is protected with a seal-able plastic cover which has the appropriate holes to access the **RESET**, **TEST** and **PROG** keys.

Generic functions of the LEDs and front keypad:

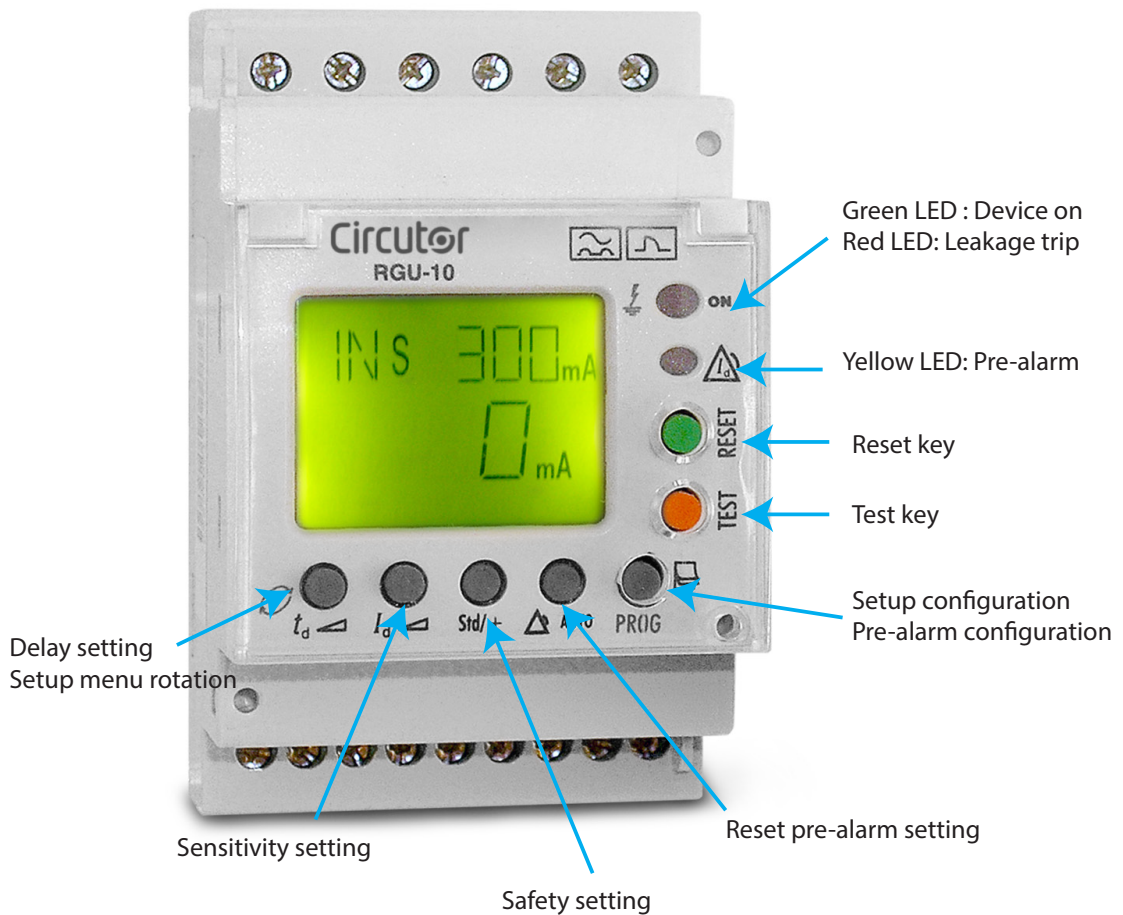

Figure 14: LEDs and keyboard description.

4.3.- LEDs INDICATORS

The device has 2 indicators LEDs, Figure 14.

Table 4: LEDs description: ON dual colour LED

ON Dual colour: Green - Red LED	
State	Description
Off	The device is not operating or is not receiving power supply voltage.
Green	The device is operating. It is receiving power supply voltage.
Red	The device has tripped.

Table 5:LEDs description: Yellow LED.

Yellow LED	
State	Description
Off	There is no pre-alarm trip.
On	Pre-alarm trip without reclosing.
On flashing	Pre-alarm trip in reclosing situation.

#### 4.4.- KEYBOARD FUNCTIONS

The device has 7 keys, Figure 14.

##### 1.- Keys accessible with sealed cover and tool.

- ✓ **RESET**, Starts the equipment after a trip.
- ✓ **TEST**, Carries out a trip to check the proper operation of the relay.
- ✓ **PROG/PAG**, The function of the key depends on the duration of the touch.

Table 6:Operation of the PROG/PAG key.

Key	Operation
PROG/PAG	Short press
	Access to Pre-alarm programming.
	Long press
	Access to the programming of the device by Setup.

##### 2.- Keys accessible with cover raised

Keys with dual function. With a long press, the device is entered to set the values. With a short press, the option within a series of values defined in the device is selected.

- ✓ **SENSITIVITY**,
  - It allows to choose between the values of 30, 100, 300, 500 mA, 1 and 3 A
  - This scale can be extended using the SETUP program to add 5, 10 and 30 A to the above values.
- ✓ **DELAY**,
  - It allows to choose between the values of 20, 100, 200, 300, 400, 500, 750 ms and 1s.
  - This scale can be extended using the SETUP program to add 3, 5 y 10 s to the above values.
  - This key also allows navigation within the SETUP MENU.

##### 3.- Keys accessible with sealed cover and tool.

Flush buttons.

- ✓ **SAFETY**, This allows the output contacts' polarity to be set for both the main relay and the pre-alarm.
  - With normal safety (Std) the relay is activated with a fault, the status is NO.
  - With positive safety (+) the relay is activated on supplying the device and is deactivated with

the fault, the status is NC.

- ✓ **RESET PRE-ALARM**, This allows the automatic re-establishment of the pre-alarm signal to be enabled.
  - In Automatic Mode (REC), if the detected leakage current is below the preset pre-alarm threshold, the relay becomes de-activated.
  - In manual mode, the device has to be RESET from the alarm screen in order to re-establish the pre-alarm system.

#### 4.5.- DISPLAY

The device has a backlit display with green or red light, depending on the state of the device.

The background to the screen in normal mode is green. The parameters required for earth leakage protection, sensitivity and delay in its associated units are displayed. It also displays the current leakage current.

If the device trips through any event, the screen’s background changes to red and the reason for the trip is displayed.

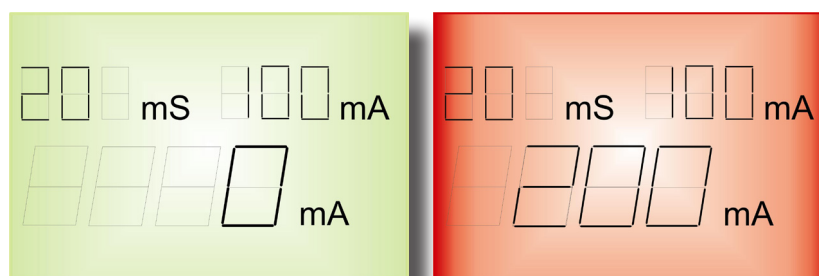

Figure 15: Display RGU-10.

Display messages by device trip, **Table 7**.

Table 7: Display messages by device trip

Message	Cause of trip
TEST	Test
EXT	Remote signal ON/OFF
REM	RS-485 Communications
Instant value	Current leakage

Other display messages, **Table 8**.

Table 8: Other display messages.

Message	Description
SAVE	Validate configuration values
EXIT	Exits programming mode
ERRt	Poor toroid connection
OVR	Current leakage reading off scale



4.6.- OPERATION

When the device is powered at its rated voltage, the green LED **ON** the front is on, the backlit LCD is green indicating the software and hardware version. After a short while, the version disappears and the default display values appear on the display.



Figure 16:Initial screens.

The display shows the delay and sensitivity settings as well as the instant leakage current reading.

While the device is operating, the display shows the following symbols while the device is being programmed and set, **Figure 17**.

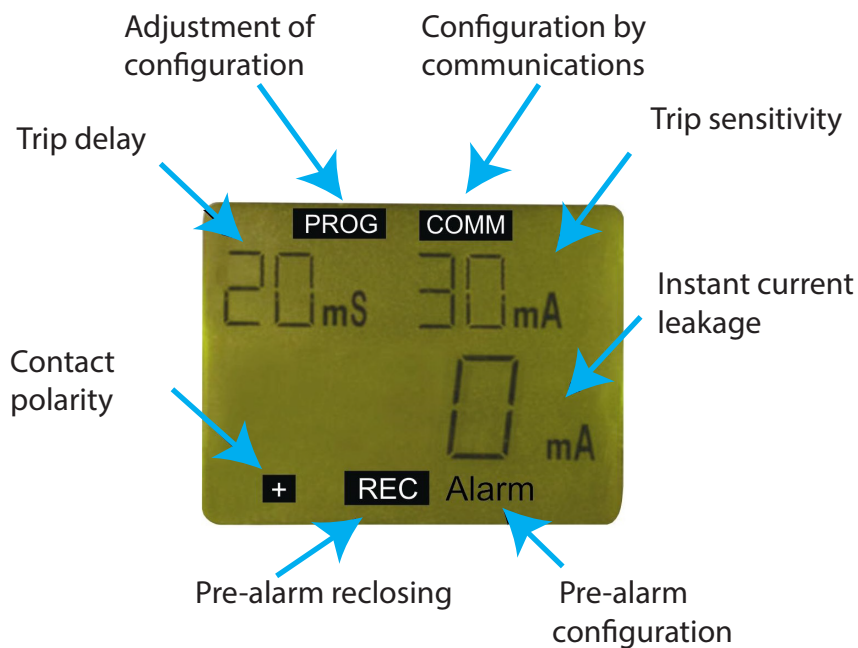

Figure 17: Display description.

In normal operating status the display shows the following parameters associated with the earth leakage protection. **Table 9**.

Table 9: Parameters visible by display.

Parameter	Units
Instant current leakage	mA / A
Programmed trip delay, $t_d$	ms / s
Programmed sensitivity of trip , $I_d = I\Delta n$	mA / A
Main relay contact status	+ (contact 14-15 NO) / nothing (contact 14 - 15 NC) + (contact 16-15 NC) / nothing (contact 16 - 15 NO)

The **RGU-10 / RG5-10C** allow the display and setting of all required parameters to complete the earth leakage protection adjustment with pre-alarm and communications.

Table 10: Adjustment parameters.

Parameter	Units
Programmed pre-alarm trip delay	ms / s
Sensitivity of pre-alarm in % $I_{\Delta N}$	%
Pre-alarm relay contact status	+ (contact 6-5 NO) / nothing (contact 6 - 5 NC) + (contact 4-5 NC) / nothing (contact 4 - 5 NO)
Operating frequency <sup>(1)</sup>	Hz
Peripheral No <sup>(1)</sup>	-
Baud rate <sup>(1)</sup>	Bauds
Type of parity <sup>(1)</sup>	-

<sup>(1)</sup> **RGU-10C** only.

## 4.7.- TROUBLESHOOTING OR REASONS FOR TRIPPING

### 4.7.1.- POOR TOROID CONNECTION ALARM

After a certain time the device will carry out a test to detect the presence of the sensor or associated earth leakage transformer.

Also the "**ERRT**" error message will permanently appear on the **RGU-10** display.

A short-circuit in the transformer secondary will also be detected as an error.

When this error is detected, the correct connection with the earth leakage transformer has to be ensured and a **RESET** made to re-establish proper working. If the transformer is detected again, normal status is returned and the error message disappears.

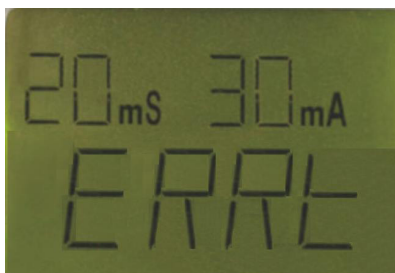

Figure 18: Alarm by poor toroid connection.

### 4.7.2.- PRE-ALARM TRIP

In the event of the defaults current exceeding the programmed pre-alarm threshold, the yellow LED will come on, the green backlit LCD will show the leakage level and the pre-alarm output relay will be activated.

In automatic mode (**REC**) when the pre-alarm situation is removed, normal status is resumed (LED and signal relay).

In manual mode, the device has to be **RESET** to unblock the pre-alarm.

#### 4.7.3.- FAULT TRIP

When the device is tripped by a current fault, the red and yellow LED comes on and the backlit LCD is red. There remains the display of the current of the last cycle that the relay has tripped. To reconnect press **RESET** to return to the initial status.

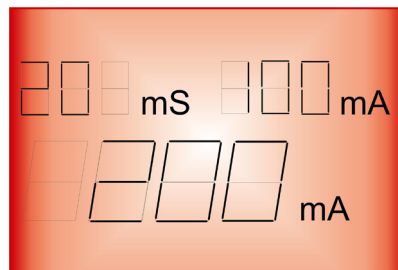

Figure 19: Fault trip.

#### 4.7.4.- REMOTE TRIP

When a trip is forced (input terminals 1-2, by applying **230 V**) the device is tripped and disabled and an "EXT" message is shown on the display in red and also the LED is on. It has to remain permanently in this situation until the change in status no longer exists. It is not possible to manually reset or reset using communications.

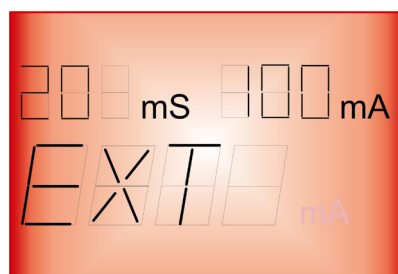

Figure 20: Remote trip.

When it is remotely reset (input terminals 1-2, removing the **230 Vac**) the equipment is reconnected with the display backlit in green, LED **ON** in green as in normal status.

For the **RGU-10C**, a remote trip/reset can also be made via RS-485 communications. The device remains tripped showing this incidence on the display with a "REM" message in red with also the LED **ON**. It has to remain permanently in this situation until the change in status no longer exists.

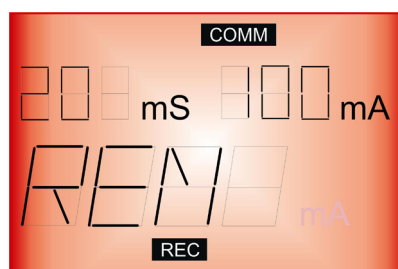

Figure 21: Remote trip via RS-485.

It is reset when the remote reset is carried out using RS-485 communications, applying 230 Vac between the remote 1-2 input terminals or by pressing the **RESET** button. The device is reconnected with the display backlit in green, LED **ON** in green as in normal status.

## 5.- CONFIGURATION

### 5.1.- DIRECT SETTING

By pressing for a long time on any of the direct setting buttons, **PROG** mode is entered (icon on display) and the relay's setting may be changed.

While in **PROG** mode if any other direct function is used (**Id**, **td**, **Std/+ y Auto**), the parameter for the displayed relay can also be set.

**PROG** mode is exited if no buttons are pressed for a while with the last setting being "SAVE".

#### 5.1.1.- SETTING THE SENSITIVITY TRIP

Pressing **Id** for more than one second, **PROG** appears and a setting from the list is increased with every press. The current setting is seen in small figures and the new setting in the main figures.

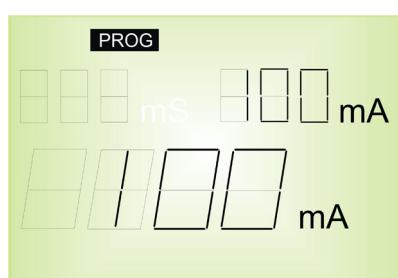

Figure 22: Setting the sensitivity trip.

Possible setting values are: 30 mA, 100 mA, 300 mA, 500 mA, 1 A, 3 A, 5 A, 10 A and 30 A.

**Note:** The scale is limited, this is changed in the device's **SETUP**. The default setting is a 3A scale.

#### 5.1.2.- DELAY SETTING AND MAIN RELAY CURVE

Pressing **td** for more than one second, **PROG** appears and a setting from the list including curve types is increased with every press.

The current setting is seen in small figures and the new setting in the main figures.

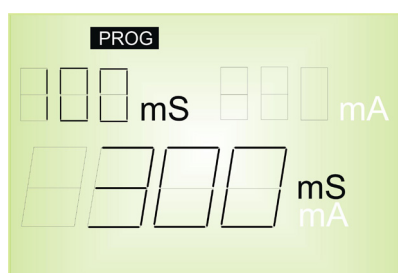

Figure 23: Delay setting.

Possible setting values are: **INS curve**, **SEL [S] curve**, 20, 100, 200, 300, 400, 500, 750 ms, 1, 3, 5 and 10 s.

**Note:** The scale is limited, this is changed in the device's **SETUP**. The curves belong to the 1 s scale which is the default scale.

**Note:** If the setting for **IΔN** is 30 mA, only instant settings are permitted: 20 ms, **INS curves** or **SEL**.

### 5.1.3.- POSITIVE SECURITY SETTING OF THE MAIN RELAY

"Std", contacts are on standby, terminals 14 - 15 (NC) and 13 - 15 (NO).

"+", contacts change status on powering the device, the + sign is displayed. Terminals 14 -15 (NO) and 13 -15 (NC).

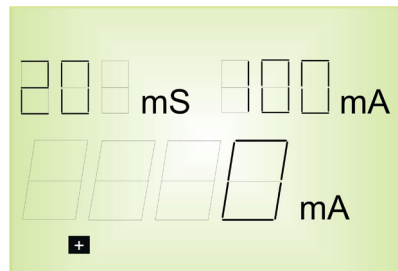

Figure 24: Positive security setting.

### 5.1.4.- SETTING THE PRE-ALARM RELAY

The **PROG/PAG** key control the pre-alarm relay and main relay settings using **SETUP**.

If the button is pressed for a short time the pre-alarm setting is entered. "Alarm" appears on the display. Also the pre-alarm threshold appears as a % of the sensitivity setting and the pre-alarm delay. To exit press **PROG**.

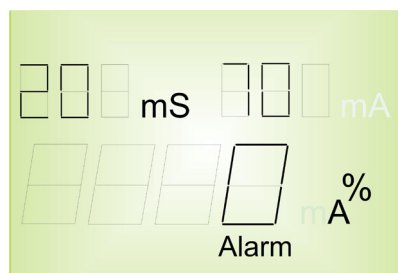

Figure 25: Setting the pre-alarm relay.

#### 5.1.4.1.- Setting of the pre-alarm current

This is in terms of the program value in the main relay. Pressing **Id** enters to change the value. Relative values are shown as a % of the preset trip current. Pressing **Id** changes the values: **OFF**, **50**, **60**, **70**, **80** and **MAIN**.

Where:

**OFF**: pre-alarm disabled

**MAIN**: the pre-alarm continues to trip the main channel.

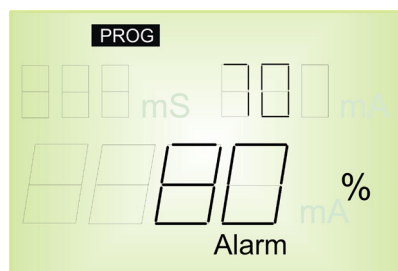

Figure 26: Setting of the pre-alarm current.

### 5.1.4.2.- Pre-alarm time setting

This is in terms of the program value in the main relay. Pressing **td** enters to change the values. Pressing **td** changes the values: 20, 50, 75, 100, 300, 500, 750 ms, 1, 3, 5 and 10 s.

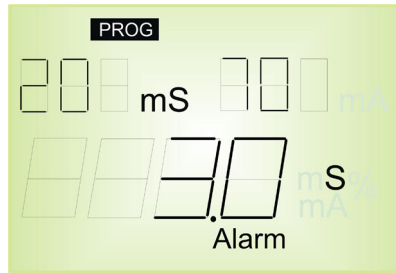

Figure 27: Pre-alarm time setting.

### 5.1.4.3.- Pre-alarm positive safety setting

“Std”, contacts are on standby . Terminals : 4 - 5 (NC) and 6 - 5 (NO).

“+”, contacts change status on powering the device, the + sign is displayed. Terminals :4 – 5 (NO) and 6 – 5 (NC).

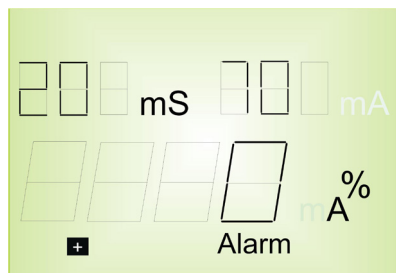

Figure 28: Pre-alarm positive safety setting.

### 5.1.4.4.- Reset pre-alarm setting

In the pre-alarm menu the **REC** function is shown as disabled or enabled. **REC** appears on the display when it is enabled.

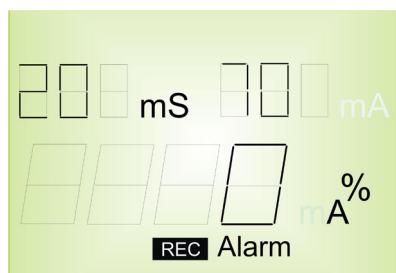

Figure 29: Reset pre-alarm setting.

5.2.- SETTING BY SETUP

“PROG” and the first menu option appear on the display by pressing a long time the **PROG/PAG** key. Once in menu setting mode, the different text indicators appear on the display after each time **PROG** is pressed.

When the correct menu is reached, the parameter can be changed by pressing **td** (rotating). In order to enter the settings press the **PROG** but on again with the “SAVE” message showing the version of the device. The display the turns to the initial screen.

If, after a certain time, the keyboard remains inactive the “EXIT” message appears and the main relay settings are shown without any information being saved.

A.- RGU-10C configuration menu

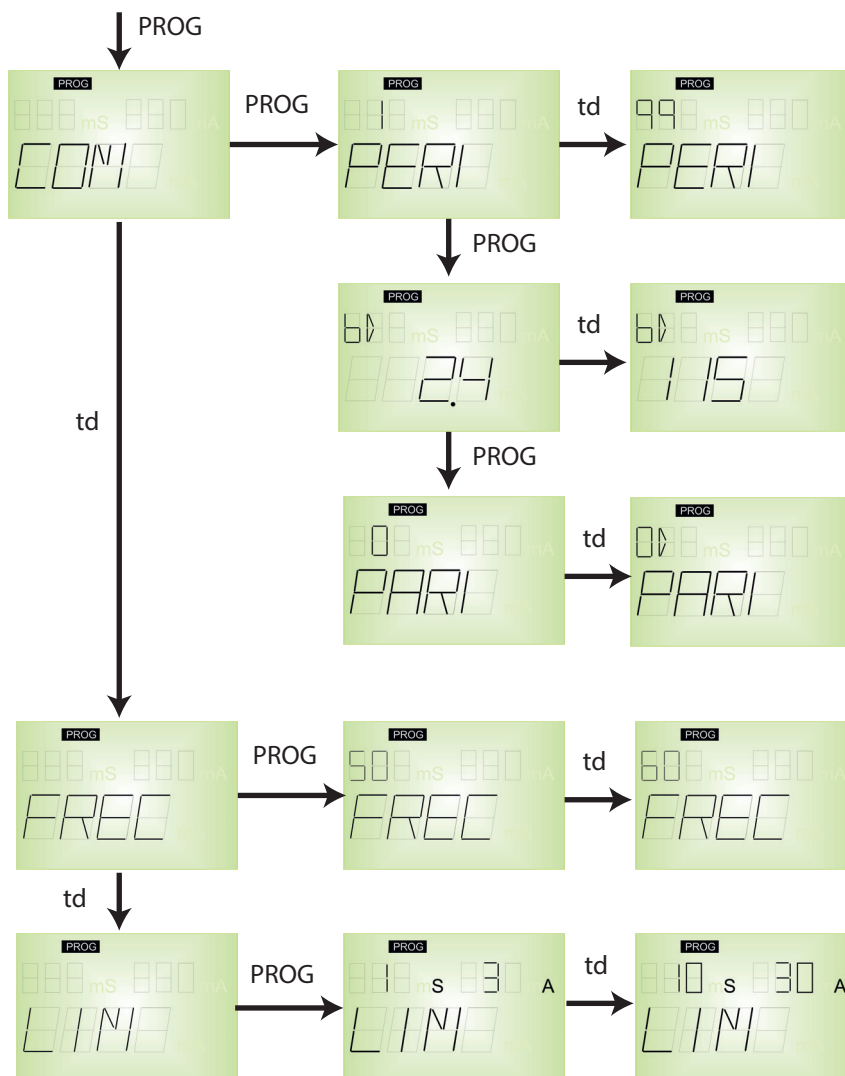

Figure 30: RGU-10C configuration menu.

B.- RGU-10 configuration menu



Figure 31: RGU-10 configuration menu.

5.3.- CONFIGURATION THE MEASUREMENT SETUP

From measurement SETUP, the parameter settings for the **RGU-10/RGU-10C** can be displayed and/or changed; this may match these parameters to the requirements of the system topologies and/or applications

If it is an **RGU-10C**, this SETUP menu is preceded by the communications SETUP menu. If there is no communications, **RGU-10**, is the only SETUP on the device.

The device does not save the setting changes until all of the setting has been entered using the **PROG** key. When it detects that the keyboard has been inactive for a certain time it displays "EXIT" and the setting menu is exited it without saving the changes.

On entering configuration mode, a screen is displayed informing that the device has entered configuration mode with the **PROG** symbol on the upper section of the first menu screen.

5.3.1.- OPERATING FREQUENCY

The display shows **FREQ**. In order to change this press **PROG**. The value of the current frequency appears on the upper left of the screen



In order to change the operating frequency, repeatedly press the **td** button increase in the digit in the upper left corner.

When the value on the screen is the required value, enter and move onto the next menu by pressing the **PROG** key. SETUP is exited with the **SAVE** message.



### 5.3.2.- SCALE LIMIT

The display shows **LIM**. In order to change this press **PROG**. The final delay scale values and the actual current sensitivity settings appear on the upper section of the screen.

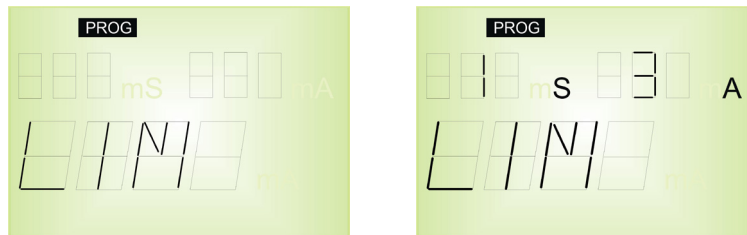

In order to modify the operational scale, repeatedly press the **td** button increasing the values of the digits on the upper section of the screen. There are two scales, one in **10 seconds** and **30 A** and the other default scale in **1 second** and **3 A**.

When the required values are shown on the screen they are entered by pressing the **PROG** button. **SETUP** is exited with the **SAVE** message.

### 5.4.- CONFIGURATION THE COMMUNICATION SETUP

**Note:** *Only for RGU-10C models.*

One or more **RGU-10C** devices may be connected to a computer or PLC in order to automate a production process or an energy control system. As well as the usual operation of each device, this system may centralize data at one single point; for this reason the **RGU-10C** has an RS-485 communication output.

If more than one device is connected to one single series line (**RS-485**), it is necessary to assign to each a number or address (from 1 to 99) so that the central computer or PLC sends the appropriate requests to these addresses for each peripheral.

From communication **SETUP**, the **RGU-10C**'s communication parameters may be displayed and/or changed; this may match these parameters to the requirements of the system topologies and/or applications.

The device does not save the setting changes until all of the setting has been entered using the **PROG** button. When it detects that the keyboard has been inactive for a certain time it displays "**EXIT**" and the setting menu is exited it without saving the changes.

To access communications **SETUP** press the **PROG** key.

On entering setting mode a screen is displayed showing that the device has entered communication setting mode.

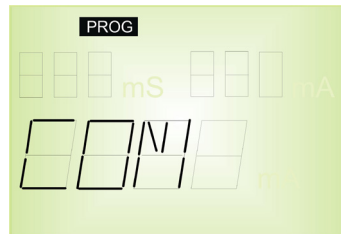

To enter setting mode the **PROG** key must be pressed.

#### 5.4.1.- PERIPHERAL NUMBER

The display shows **PERI** and the peripheral number on the upper left of the screen.

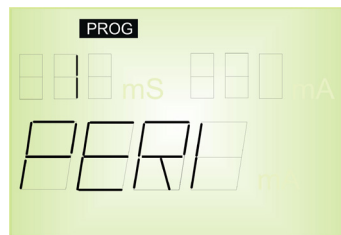

To write or change the number of the peripheral repeatedly press the **td** button, increasing the value of the digit which is in the upper left corner.

When the required value is on the screen, it is entered and the display moves on to the next menu by pressing **PROG** key, to allow the remaining values to be changed.

The peripheral number varies between **1** and **99**.

#### 5.4.2.- BAUD RATE

The display shows the letters "**bd**" on the upper left of the screen showing the bauds and shows the baud rate in units of a thousand in the central part of the screen.

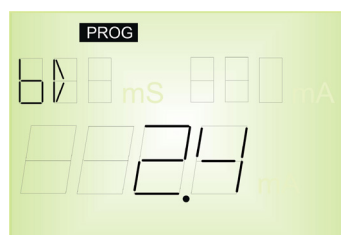

Repeatedly press the **td** button to change the baud rate, increasing the value of a digits on the central area of the screen.

When the required value is on the screen, move on to the following digit by pressing **PROG**, to allow the remaining values to be changed.

The possible setting values are as follows:

Table 11: Baud rate.

Value on screen	Bauds
2.4	2400
4.8	4800
9.6	9600
19.2	19200
38.4	38400
54.6	54600
115	115000

### 5.4.3.- PARITY

The display shows "PARI" with the set a value on the upper left of the screen.

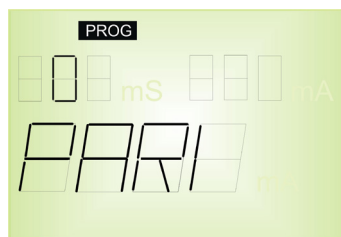

In order to change parity, repeatedly press the **td** key to change the values on the upper left of the screen.

When the required value is on the screen, it is entered and the display moves on the next screen by pressing **PROG**, to allow the setting to be changed.

For communication setting menu using SETUP ends on this screen. It directly links with the first measurement SETUP screen on the device.

6.- RS-485 COMMUNICATIONS

RGU-10C devices feature one RS-485 communications port. The device has uses the MODBUS RTU communications protocol as the standard protocol.

6.1.- CONNECTIONS

The RS-485 cable must be wired with twisted pair cable with mesh shield (minimum 3 wires), with a maximum distance between the **RGU-10C** and the master device of 1200 metres. Up to 32 **RGU-10C** devices can be connected to this bus.

Use an intelligent RS-232 to RS-485 network protocol converter to establish the communications with the master device.

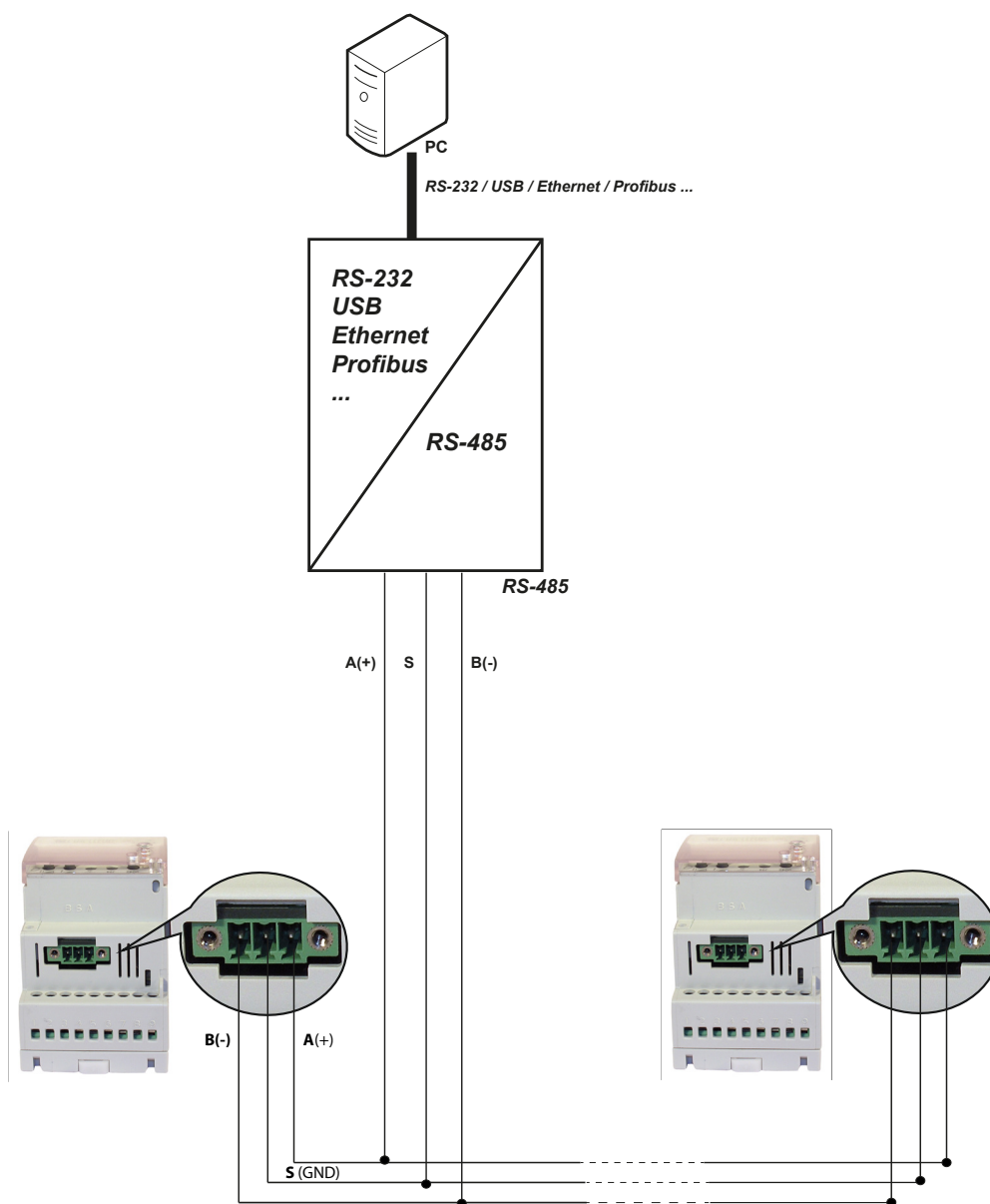

Figure 32: RS-485 Connection diagram.

## 6.2.- MODBUS PROTOCOL

In the Modbus protocol, the **RGU-10C** uses the RTU (Remote Terminal Unit) mode.  
The Modbus functions implemented in the device are as follows:

**Function 0x04:** Reading integer registers.

**Function 0x10:** Writing multiple registers.

### 6.2.1. READ EXAMPLE: Function 0x04.

Query:

Address	Function	Initial Register	No. of registers	CRC
0A	04	0000	000A	7176

**Address: 0A**, Peripheral number: 10 in decimal.

**Function: 04**, Read function.

**Initial Register:0000**, register from which to start reading.

**No. of Registers: 000A**, number of registers to be read: 10 in decimal.

**CRC: 7176**, CRC character.

Response:

Address	Function	No. of Bytes	Registers										CRC
			n° 1	n° 2	n° 3	n° 4	n° 5	n° 6	n° 7	n° 8	n° 9	n° 10	
0A	04	14	000A	0002	0000	0032	0000	0001	0000	0001	0014	0000	7EC9

**Address: 0A**, Responding peripheral number: 10 in decimal.

**Function: 04**, Read function.

**No. of bytes: 14**, No. of bytes received: 20 in decimal.

**Registers: 000A**, Address 0000h: Peripheral number : 10

**0002**, Address 00001h: Baud rate : 2 = 9600 bds

**0000**, Address 00002h: Type of parity : 0 = None

**0032**, Address 00003h: Operating frequency : 50 Hz

**0000**, Address 00004h: Trip current : 0 = 30 mA

**0001**, Address 00005h: Time for trip delay : 1 = INS

**0000**, Address 00006h: Relay output trip polarity : 0 = Standard

**0001**, Address 00007h: % IΔn trip by pre-alarm. : 1 = 50%

**0014**, Address 00008h: Time for pre-alarm delay: 1 = 20ms

**0000**, Address 00009h: Pre-alarm output relay polarity : 0 = Standard

**CRC: 7EC9**, CRC character.

**Note:** Each Modbus frame has a maximum limit of 26 registers.

6.2.2. WRITE EXAMPLE: Function 0x10.

Query:

Address	Function	Initial Register	No. of registers	N° de Bytes	Registers					CRC
					N°1	N°2	N°3	N°4	N°5	
01	10	0000	0005	0A	0001	0003	0000	003C	0000	FF64

**Address: 01**, Peripheral number: 1.

**Function: 10**, Writing multiple registers.

**Initial Register: 0000**, Initial register of writing.

**No. of bytes: 0A**, No of bytes that are sent: 10

**Registers : 0001**, Address 0000h: Peripheral number : 1

**0003**, Address 00001h: Baud rate : 3 = 19200 bds

**0000**, Address 00002h: Type of parity : 0 = None

**003C**, Address 00003h: Operating frequency : 60 Hz

**0000**, Address 00004h: trip current : 0 = 30 mA

**CRC: FF64**, CRC character.

Response:

Address	Function	Initial Register	No. of registers	CRC
01	10	0000	0005	000A

*Nota: Each Modbus frame has a maximum limit of 26 registers.*

6.3.- MODBUS COMMANDS

All Modbus map addresses are expressed in hexadecimal.

Table 12: Modbus memory map

Parameter	Symbol	Address	Reading / Writing	Values	Units
Peripheral No.	PERI	0000	R/W	1 - 99	-
Baud rate	bd	0001	R/W	2400-4800-9600-19200-38400-57600-115200	bauds
Type of parity	PARI	0002	R/W	None - Odd - Even	-
Operating frequency	FREC	0003	R/W	50 - 60	Hz
Trip current Main relay	ld	0004	R/W	0.03 - 0.1 - 0.3 - 0.5 - 1 - 3 - 5 - 10	A
Delay time Main relay	td	0005	R/W	INS - SEL - 0.02 - 0.1 - 0.3 - 0.4 - 0.5 - 0.75 - 1 - 3 - 5 - 10	s
Contact polarity Main relay	Std/+	0006	R/W	Standard - Positive	-
Trip current Pre-alarm	ld'	0007	R/W	OFF - 50 - 60 - 70 - 80	%
Delay time Pre-alarm	td'	0008	R/W	0.02 - 0.1 - 0.2 - 0.3 - 0.4 - 0.5 - 0.75 - 1 - 3 - 5 - 10	s
Contact polarity Pre-alarm	Std/+	0009	R/W	Standard - Positive	-
Pre-alarm reclosing	REC	000A	R/W	Manual - REC	-

Table 12 (Continuation) : Modbus memory map

Parameter	Symbol	Address	Reading / Writing	Values	Units
Series No. (HI)	-	000B	R	18AD - 188C	-
Series No. (LO)	-	000C	R	0000 - FFFF	-
Device version	-	000D	R	0 -100	-
Relay contacts status	-	0014	R	off - on (main) on (pre-alarm)	-
Effective value Current leakage	-	0015	R	0 - 65.000	mA
Effective value Trip current.	-	0016	R	0 - 65.000	mA
Trip and external reset	-	0019	W	0000 : Reset FFFF : Test	-
Enable setting saving	-	001A	W	0000 : Enable FFFF : Save	-

**7.- TECHNICAL FEATURES**

Power supply CA				
Rated voltage <sup>(2)</sup>	230 V ~ ± 20%	110 V ~± 20%	400 V ~ ± 20%	24 ... 48 V ~
Frequency	50 - 60 Hz			
Consumption	6 VA			

Power supply CC	
Rated voltage <sup>(2)</sup>	24 ... 125 V ===
Consumption	4 W

<sup>(2)</sup> Depending on model.

Main relay / Pre-alarm output	
Rated current	6 A ~
Maximum instant current	10 A ~
Rated voltage	230 V ~ / 400 V ~ <sup>(2)</sup>
Maximum switching voltage	250 V ~
Rated load in CA	2500 VA
Contacts protected by varistor	275 V ~
Mechanical useful life	10 x 10 <sup>6</sup>
Ambient temperature range	- 40 ... 85 °C

Electrical useful life for AC loads	
-------------------------------------	--





Cut off power for DC loads	
----------------------------	--

**Note:** Circuitor guarantees that the RGU-10 / RGU-10C device complies with a response time of less than 30 ms to 5In, and in combination with the selected cutting element must guarantee a total cut-off time of less than 40 ms to comply with the IEC 60947-2-M standard.

External voltage input ON/OFF	
Type	Optocoupled
Maximum voltage	110 - 230 V ~± 20%
Maximum power	0.7 W

Earth leakage current measurement circuit		
Scale range	Full scale	Resolution Display
30 mA	75 mA	± 1 mA
300 mA	750 mA	± 1 mA
3 A	7.5 A	± 0.1 A
30 A	75 A	± 1 A



Communications ( RGU-10C model)				
Bus	RS-485			
Communications protocol	Modbus RTU			
Baud rate	2400 - 4800 - 9600 - 19200 - 38400 - 57600 - 115200 bauds			
Stop bits	1			
Parity	without - even - odd			
User interface				
Display	LCD			
Keyboard	7 keys			
LED	2 LEDs			
Environmental features				
Operating temperature	-10°C ... +50°C			
Relative humidity (without condensation)	5 ... 95%			
Maximum altitude	2000 m			
Protection degree	Mounted device: IP41 (Frontal) Device without mounted : IP20 (Sides and back cover)			
Mechanical features				
Dimensions	Figure 33			
Weight	236 g.			
Enclosure	V0 self-extinguishing plastic			
Fijación	DIN rail			
Connections				
	7 mm	0.127 ... 2.082 mm <sup>2</sup>	0.5 ... 0.6 Nm	stair road 0.4x2.5x80 mm

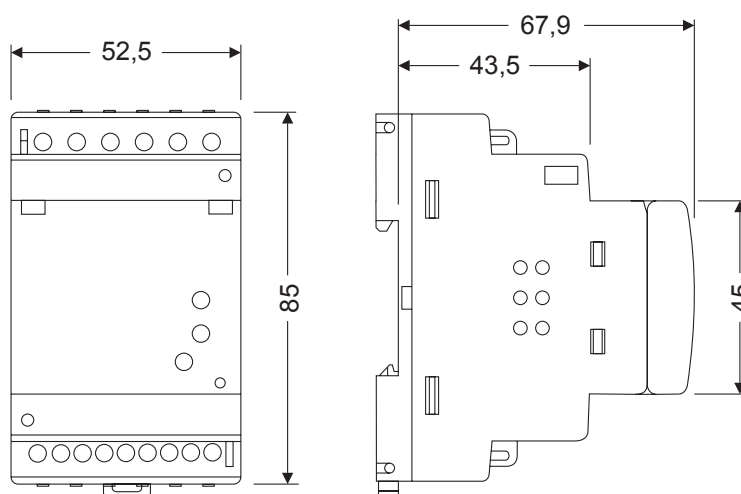

Figure 33: RGU-10 dimensions.

Safety / Standard	
Designed for installations category III 300 V~ (EN 61010)	
Protection against electric shock by class II double insulation.	
Electrical accessories - Residual current monitors for household and similar uses (RCMs)	IEC 62020
Low-voltage switchgear and controlgear -- Part 2: Circuit-breakers	IEC 60947-2-M
General requirements for residual current operated protective devices	IEC 60755
Residual current operated circuit-breakers without integral overcurrent protection for household and similar uses (RCCBs) - Part 1: General rules	IEC 61008-1

## 8.- TECHNICAL SERVICE

In the case of any query in relation to device operation or malfunction, please contact the **CIRCUTOR SA** Technical Support Service.

### Technical Assistance Service

Vial Sant Jordi, s/n, 08232 - Viladecavalls (Barcelona)

Tel: 902 449 459 ( España ) / +34 937 452 919 (outside of Spain)

email: sat@circutor.com

## 9.- WARRANTY

**CIRCUTOR** guarantees its products against any manufacturing defect for two years after the delivery of the units.

**CIRCUTOR** will repair or replace any defective factory product returned during the guarantee period.



- No returns will be accepted and no unit will be repaired or replaced if it is not accompanied by a report indicating the defect detected or the reason for the return.
- The guarantee will be void if the units has been improperly used or the storage, installation and maintenance instructions listed in this manual have not been followed. "Improper usage" is defined as any operating or storage condition contrary to the national electrical code or that surpasses the limits indicated in the technical and environmental features of this manual.
- **CIRCUTOR** accepts no liability due to the possible damage to the unit or other parts of the installation, nor will it cover any possible sanctions derived from a possible failure, improper installation or "improper usage" of the unit. Consequently, this guarantee does not apply to failures occurring in the following cases:
  - Overvoltages and/or electrical disturbances in the supply;
  - Water, if the product does not have the appropriate IP classification;
  - Poor ventilation and/or excessive temperatures;
  - Improper installation and/or lack of maintenance;
  - Buyer repairs or modifications without the manufacturer's authorisation.

10.- CE CERTIFICATE



**DECLARACIÓN UE DE CONFORMIDAD**

La presente declaración de conformidad se expide bajo la exclusiva responsabilidad de CIRCUITOR con dirección en Vial Sant Jordi, s/n – 08232 Viladecavalls (Barcelona) España

Producto:

**Reles diferenciales para transformadores WGC, tipo A ultrainmunizados, 3 módulos y display**

Serie:

**RGU-10, RGU-10C, RGU-10 RAL**

Marca:

**CIRCUITOR**

EL objeto de la declaración es conforme con la legislación de armonización pertinente en la UE, siempre que sea instalado, mantenido y usado en la aplicación para la que ha sido fabricado, de acuerdo con las normas de instalación aplicables y las instrucciones del fabricante

**2014/35/UE: Low Voltage Directive 2014/30/UE: Electromagnetic Compatibility Directive**

**2011/65/UE: RoHS2 Directive**

Está en conformidad con la(s) siguiente(s) norma(s) u otro(s) documento(s) normativos(s):

IEC 60947-2:2006-AMD1:2009-AMD2:2013 CSV164.2 Annex M

Año de marcado "CE":

1996



**EU DECLARATION OF CONFORMITY**

This declaration of conformity is issued under the sole responsibility of CIRCUITOR with registered address at Vial Sant Jordi, s/n – 08232 Viladecavalls (Barcelona) Spain

Product:

**Earth leakage relays for WGC transformers, 3 modules, display**

Series:

**RGU-10, RGU-10C, RGU-10 RAL**

Brand:

**CIRCUITOR**

The object of the declaration is in conformity with the relevant EU harmonisation legislation, provided that it is installed, maintained and used for the application for which it was manufactured, in accordance with the applicable installation standards and the manufacturer's instructions

**2014/35/UE: Low Voltage Directive 2014/30/UE: Electromagnetic Compatibility Directive**

**2011/65/UE: RoHS2 Directive**

It is in conformity with the following standard(s) or other regulatory document(s):

IEC 60947-2:2006-AMD1:2009-AMD2:2013 CSV164.2 Annex M

Year of CE mark:

1996



**DECLARATION UE DE CONFORMITÉ**

La présente déclaration de conformité est délivrée sous la responsabilité exclusive de CIRCUITOR dont l'adresse postale est Vial Sant Jordi, s/n – 08232 Viladecavalls (Barcelona) Espagne

Produit:

**Relais différentiels pour transformateurs WGC, 3 modules avec display**

Série:

**RGU-10, RGU-10C, RGU-10 RAL**

Marque:

**CIRCUITOR**

L'objet de la déclaration est conforme à la législation d'harmonisation pertinente dans l'UE, à condition d'avoir été installé, entretenu et utilisé dans l'application pour laquelle il a été fabriqué, conformément aux normes d'installation applicables et aux instructions du fabricant

**2014/35/UE: Low Voltage Directive 2014/30/UE: Electromagnetic Compatibility Directive**

**2011/65/UE: RoHS2 Directive**

Il est en conformité avec la(les) suivante(s) norme(s) ou autre(s) document(s) réglementaire(s):

IEC 60947-2:2006-AMD1:2009-AMD2:2013 CSV164.2 Annex M

Année de marquage « CE »:

1996



Viladecavalls (Spain), 05/10/2017  
General Manager: Ferran Gil Torné



CIRCUITOR, SA – Vial Sant Jordi, s/n  
08232 Viladecavalls (Barcelona) Spain  
(+34) 937 452 900 – info@circutor.com



**KONFORMITÄTSERKLÄRUNG UE**

Vorliegende Konformitätserklärung wird unter alleiniger Verantwortung von CIRCUITOR mit der Anschrift, Vial Sant Jordi, s/n – 08232 Viladecavalls (Barcelona) Spanien, ausgestellt

Produkt:

**Differenzstromrelais für Wandler WGC, 3 Module mit Display**

Serie:

**RGU-10, RGU-10C, RGU-10 RAL**

Marke:

**CIRCUITOR**

Der Gegenstand der Konformitätserklärung ist konform mit der geltenden Gesetzgebung zur Harmonisierung der EU, sofern die Installation, Wartung und Verwendung der Anwendung seinem Verwendungszweck entsprechend gemäß den geltenden Installationsstandards und der Vorgaben des Herstellers erfolgt.

**2014/35/UE: Low Voltage Directive 2014/30/UE: Electromagnetic Compatibility Directive 2011/65/UE: RoHS2 Directive**

Es besteht Konformität mit der/den folgender/folgenden Norm/Normen oder Regelwerk/Regelwerken

IEC 60947-2:2006+AMD1:2009+AMD2:2013 CS1642 Annex M

Jahr der CE-Kennzeichnung:

1996



**DECLARAÇÃO DA UE DE CONFORMIDADE**

A presente declaração de conformidade é expedida sob a exclusiva responsabilidade da CIRCUITOR com morada em Vial Sant Jordi, s/n – 08232 Viladecavalls (Barcelona) Espanha

Produto:

**Relés diferenciais para transformadores WGC, 3 módulos**

Série:

**RGU-10, RGU-10C, RGU-10 RAL**

Marca:

**CIRCUITOR**

O objeto da declaração está conforme a legislação de harmonização pertinente na UE, sempre que seja instalado, mantido e utilizado na aplicação para a qual foi fabricado, de acordo com as normas de instalação aplicáveis e as instruções do fabricante.

**2014/35/UE: Low Voltage Directive 2014/30/UE: Electromagnetic Compatibility Directive 2011/65/UE: RoHS2 Directive**

Está em conformidade com a(s) seguinte(s) norma(s) ou outro(s) documento(s) normativo(s):

IEC 60947-2:2006+AMD1:2009+AMD2:2013 CS1642 Annex M

Ano de marcação "CE":

1996



**DICHIARAZIONE DI CONFORMITÀ UE**

La presente dichiarazione di conformità viene rilasciata sotto la responsabilità esclusiva di CIRCUITOR, con sede in Vial Sant Jordi, s/n – 08232 Viladecavalls (Barcellona) Spagna

prodotto:

**Relè differenziali per trasformatori WGC, tipo A ultraimmunizzati, 3 moduli e display**

Serie:

**RGU-10, RGU-10C, RGU-10 RAL**

MARCHIO:

**CIRCUITOR**

L'oggetto della dichiarazione è conforme alla pertinente normativa di armonizzazione dell'Unione Europea, a condizione che venga installato, mantenuto e utilizzato nell'ambito dell'applicazione per cui è stato prodotto, secondo le norme di installazione applicabili e le istruzioni del produttore.

**2014/35/UE: Low Voltage Directive 2014/30/UE: Electromagnetic Compatibility Directive 2011/65/UE: RoHS2 Directive**

È conforme alle seguenti normative o altri documenti normativi:

IEC 60947-2:2006+AMD1:2009+AMD2:2013 CS1642 Annex M

Anno di marcatura "CE":

1996



Viladecavalls (Spain), 05/10/2017  
General Manager: Ferran Gil Torné



CIRCUITOR, SA – Vial Sant Jordi, s/n  
08232 Viladecavalls (Barcelona) Spain  
(+34) 937 452 900 – info@circuitor.com



#### DEKLARACJA ZGODNOŚCI UE

Niniejsza deklaracja zgodności zostaje wydana na wyłączną odpowiedzialność firmy CIRCUITOR z siedzibą pod adresem: Vial Sant Jordi, s/n – 08232 Viladecavalls (Barcelona) Hiszpania

produkt:

Przełączniki różnicowo-prądowe dla przekładników WGC, Typu

A

Seria:

RGU-10, RGU-10C, RGU-10 RAL

marka:

CIRCUITOR

Przedmiot deklaracji jest zgodny z odnośnymi wymaganiami prawodawstwa harmonizacyjnego w Unii Europejskiej pod warunkiem, że będzie instalowany, konserwowany i użytkowany zgodnie z przeznaczeniem, dla którego został wyprodukowany, zgodnie z mającymi zastosowanie normami dotyczącymi instalacji oraz instrukcjami producenta

2014/35/UE: Low Voltage Directive 2014/53/UE: Electromagnetic Compatibility Directive

2011/65/UE: RoHS2 Directive

Jest zgodny z następującą(y)mi normą(ami) lub innym(i) dokumentem(ami) normatywnym(i):

IEC 60947-2:2006-AMD1:2008-HWD:2013 IEC 61414-1:2011

Rok oznakowania "CE":

1996



Viladecavalls (Spain), 05/10/2017  
General Manager: Ferran Gil Torné

**CIRCUTOR, SA**

Vial Sant Jordi, s/n

08232 - Viladecavalls (Barcelona)

Tel: (+34) 93 745 29 00 - Fax: (+34) 93 745 29 14

[www.circutor.es](http://www.circutor.es) [central@circutor.com](mailto:central@circutor.com)